

S
L
E
D

Sustainable Local Economic Development

Introduction

Dr. Maksadjon Rizoeva

The Economic Development Challenge:

Most frequently in Developing & Least Developed States:

- Persistent levels of poverty and Regional Disparities and inequitable access to economic growth and opportunities;
- High and growing levels of unemployment (particularly among youth and rural populations);
- Suboptimal or ineffective and inefficient use of diverse local resources and ineffective utilization of the distinctive competitive advantages of various regions;
- Divergent and in some cases, contradictory economic development policies and actions at the national level;

LED Promotion Challenge:

National Level

- Lack of alignment of Macro Economic Development Policies with LED promotion needs – Monetary, Tax, Trade, Land and others
- Limited coordination between LED relevant National Strategies and National Programs – Poverty, Employment, Private Sector, SME, Vocational Education, Industry, Agriculture and others
- Lack of clarity in the distribution of mandates and functional & resource assignment between LED relevant ministries and agencies
- Undefined division of labor for LED promotion between central and local government and limited or absent assignment of LED promotion functions and resources to local government

LED Promotion Challenge:

National Level: Macroeconomic Policies and Economic Strategies

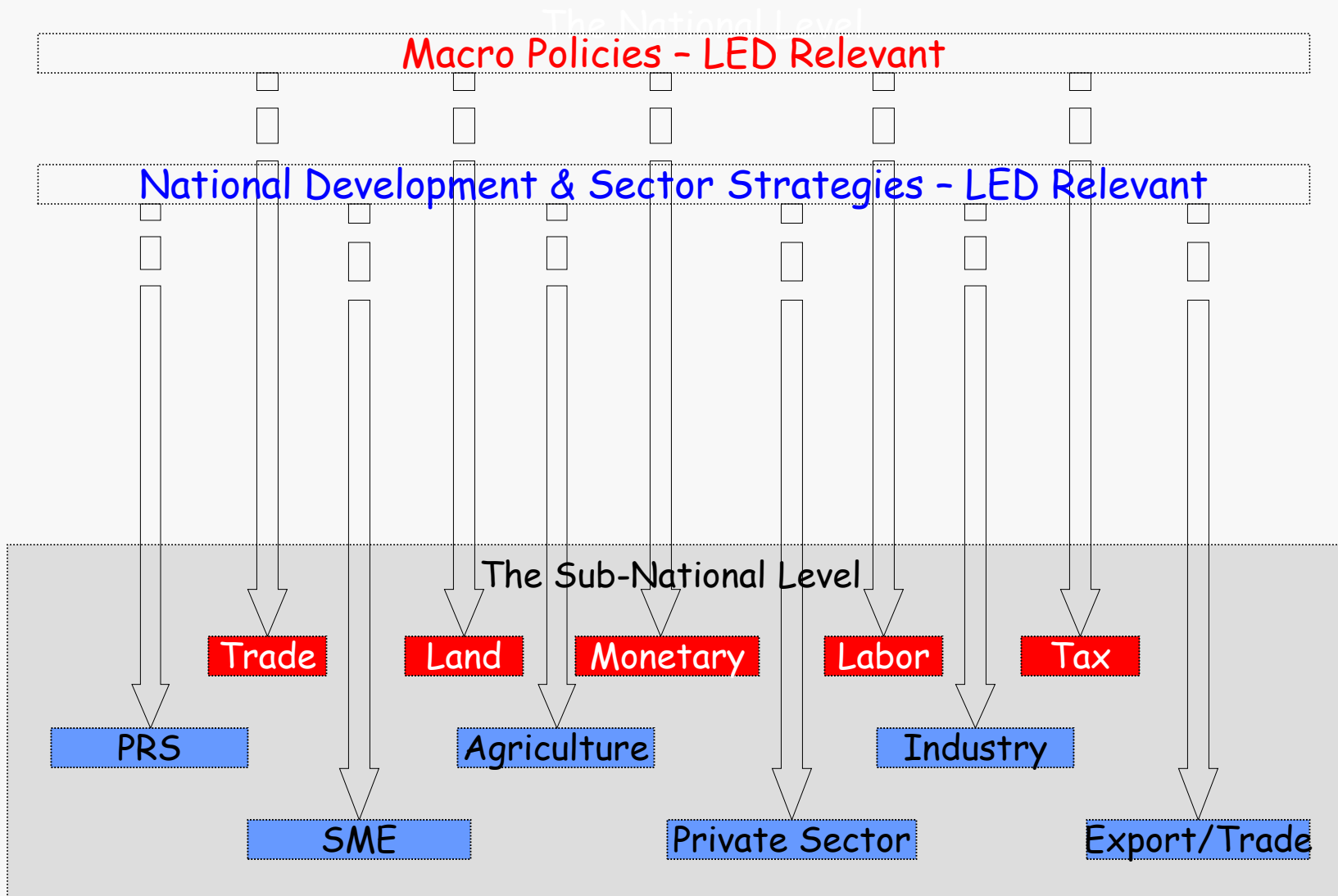

LED Promotion Challenge:

National Level: Assignment of Functions & Resources

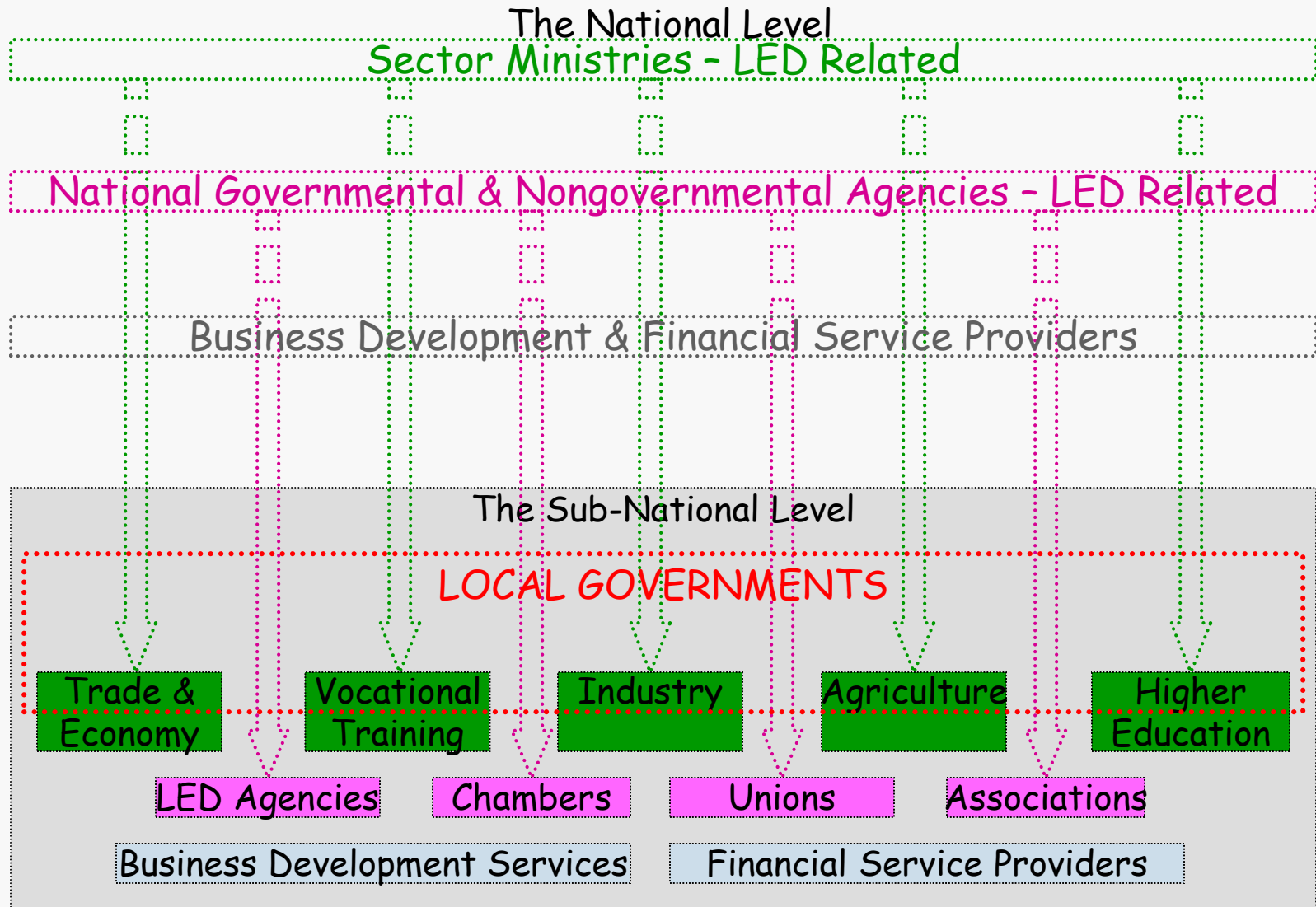

LED Promotion Challenge:

Local Level

- LED promotion functions are seldom institutionalized within mandated Local Authorities that could sustain, guide and ensure the equity of such efforts and ensure responsiveness to economic development challenges in the long-term;
- In cases where LED focused institutions exist, they may lack the tools, capacities and/or resources they need to perform this task;
- Economic development initiatives are seldom grounded in a comprehensive understanding of the target local economy, its potentials for growth and the challenges that undermine its sustainable and equitable development;
- Economic development initiatives are usually undertaken independently by individual central ministries, agencies, local administrations, private sector actors, Development Partners and others, leading to fragmentation of effort;

LED Promotion Challenge:

Local Level: The Assigned Role of Local Governments

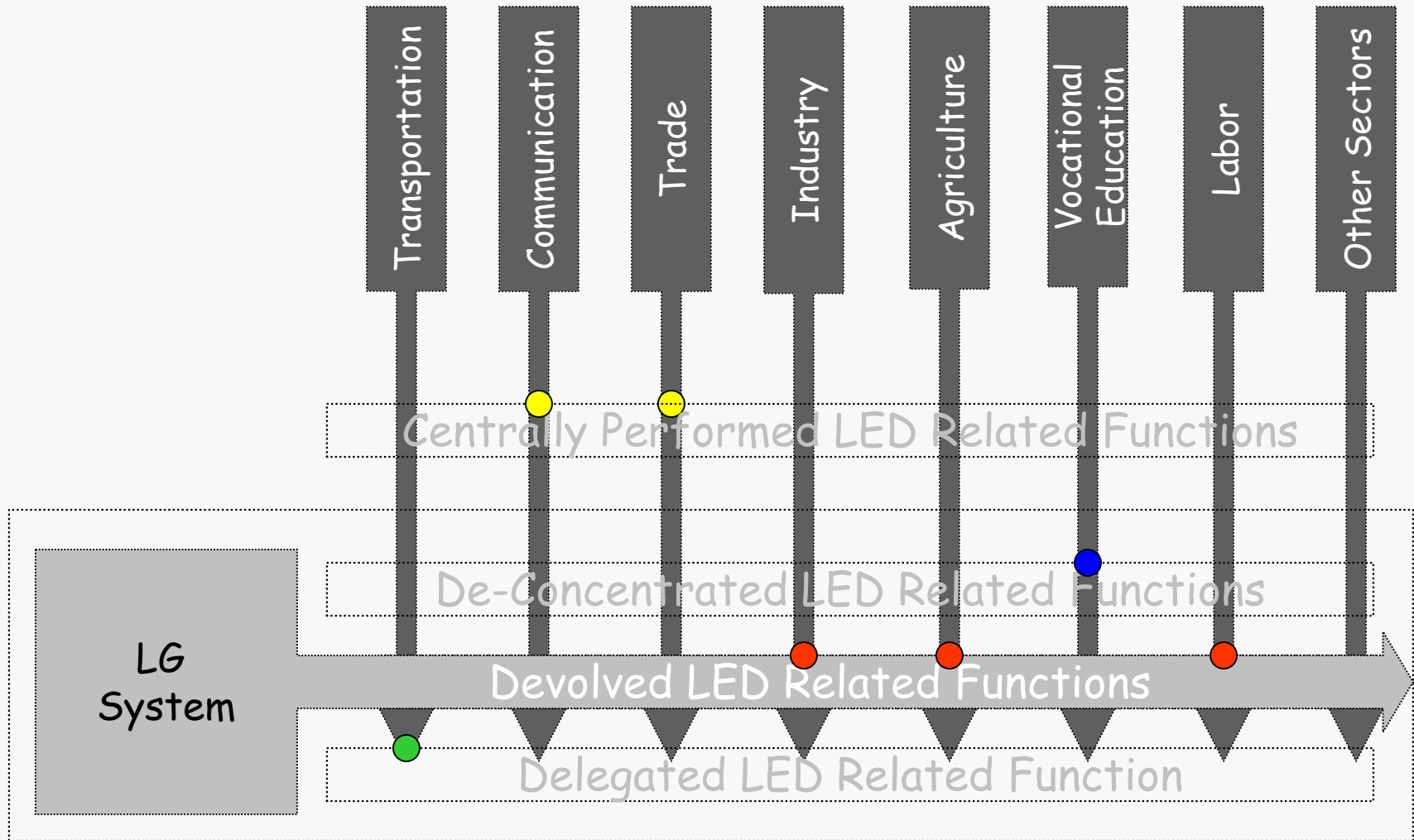

● Devolved Function

● De-Concentrated Function

● Delegated Function

● Centrally Performed Function

LED Promotion:

The Potential Role of Local Government:

✧ LED Governance:

- *Maintaining an understanding of the local economy and the prevailing business enabling environment with a supporting database;*
- *Convening economic actors, analyzing their needs, and coordinating their actions;*
- *Guiding and engaging economic actors in articulating an LED strategy and coordinating and facilitating its implementation;*
- *Maintaining emphases on equity of economic growth;*

✧ **Facilitate, Support and Coordinate the Implementation of the LED Strategy:**

- Work with economic actors on assigning roles and responsibilities for LED strategy implementation - private sector, central or de-concentrated agencies, nongovernmental or non-state actors, civil society organizations, With development partners
- Support the formation of partnerships among economic actors towards strategy implementation
- Facilitate access to technical support for less capable economic actors to enable the effective implementation of their Strategy related initiatives
- Intervene when and where appropriate to complement and strengthen the interventions of other economic actors and to reduce their risk

✧ **Contribute to LED Strategy Implementation:**

- *Investing in economic infrastructure;*
- *Entering into Public Private Partnerships appropriately;*
- *Advocating for or directly enhancing regulations;*
- *Advocating for the alignment of macroeconomic policies with LED objectives;*
- *Providing incentives – tax, land and other inputs that reduce the cost and risk of economic actors;*

The LED promotion Framework:

Systemic Empowerment of LG/LA for LED Promotion

LED Promotion:

The Core Functions and Expected Outputs of LG/LA



LED Promotion:

Going Beyond Core Local Development Functions – Specialized LD

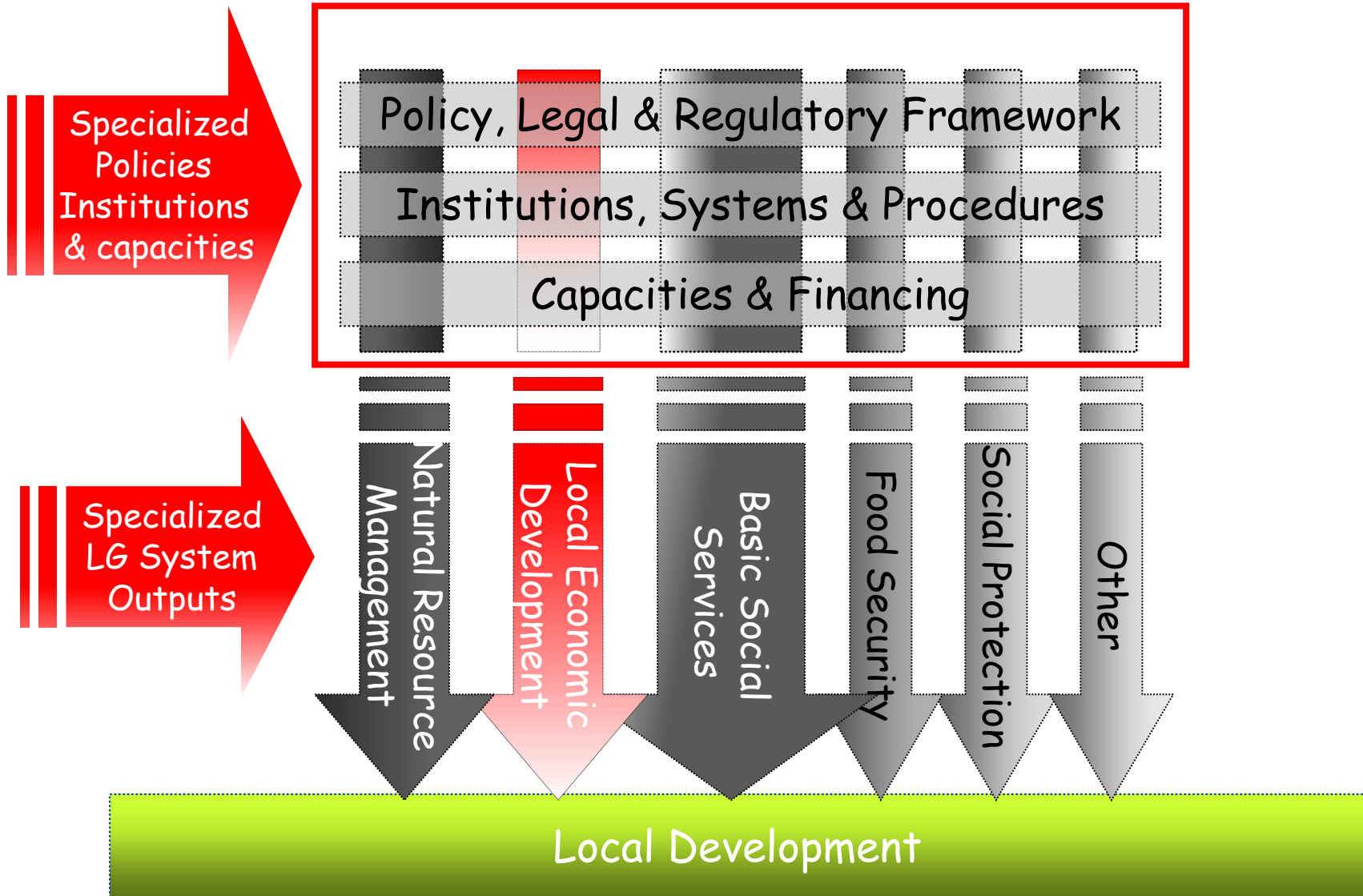

LED Promotion:

Embedding the LED Promotion Function

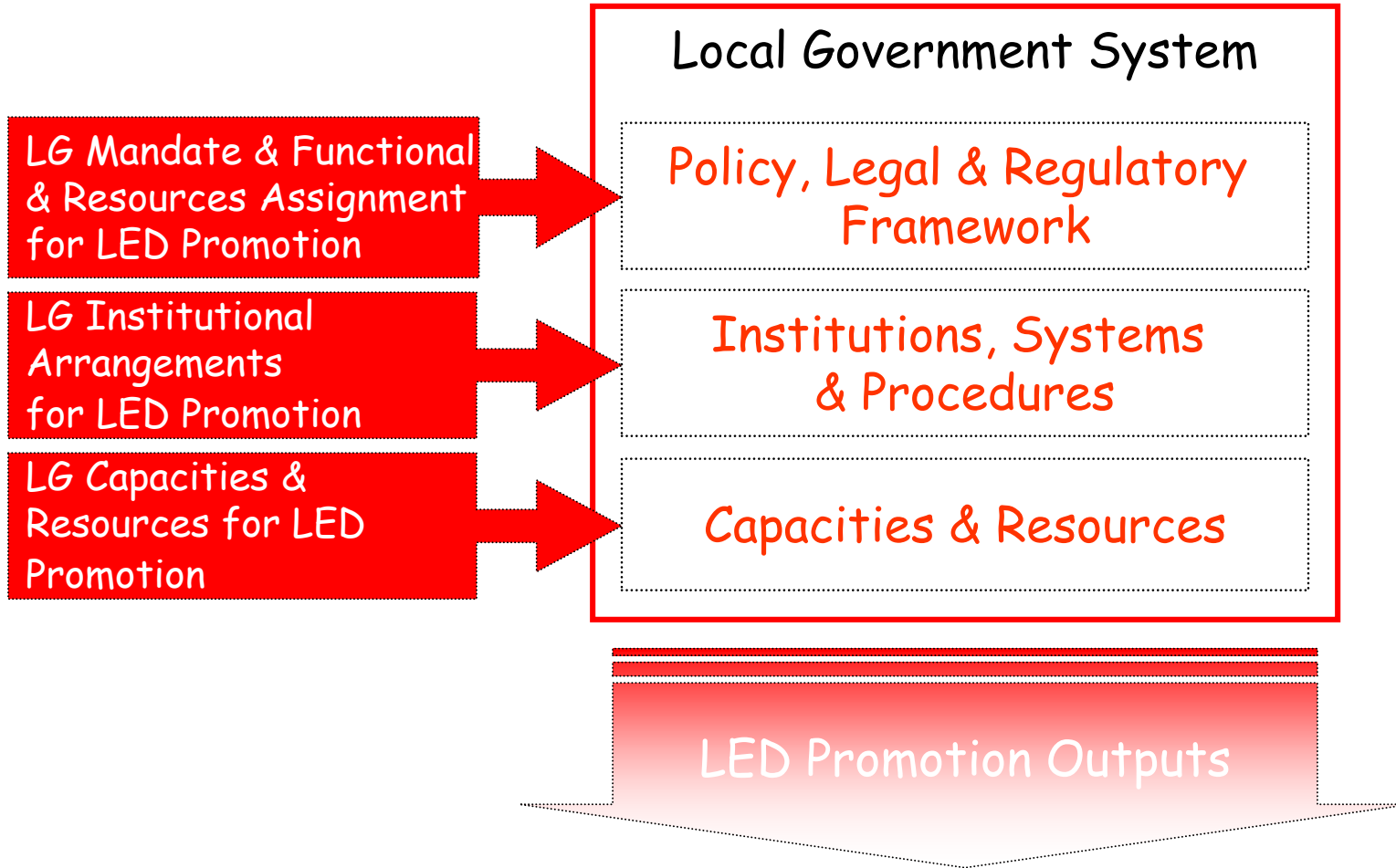

The LED promotion Framework:

Structure and Scope

The LED promotion process: Structure

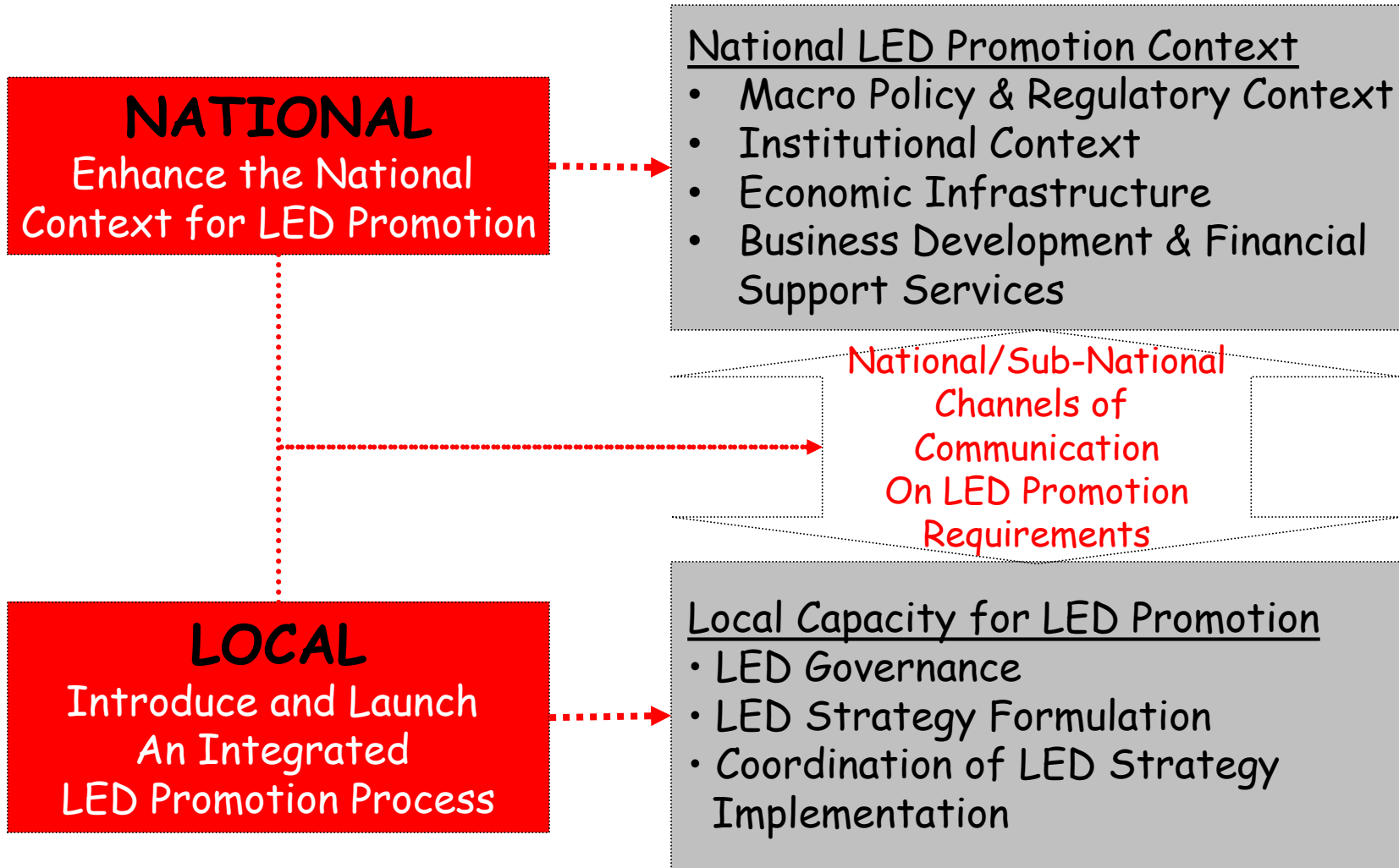

The LED promotion process:

Institutionalizing LED promotion

At the National Level;

- In Relationship to the Lead LED Promotion & Harmonization Agency (Ministry or Inter-ministerial Body)
- In Relationship to the LG Support and Supervision Agency

At the Target Locality;

- Activate the LED focused department/unit (or create a pilot entity) at Target LG Tier
- Consolidate/introduce the LED promotion staff at target LG

The LED promotion process:

LED Programme Support Structure – EGYPT Vision

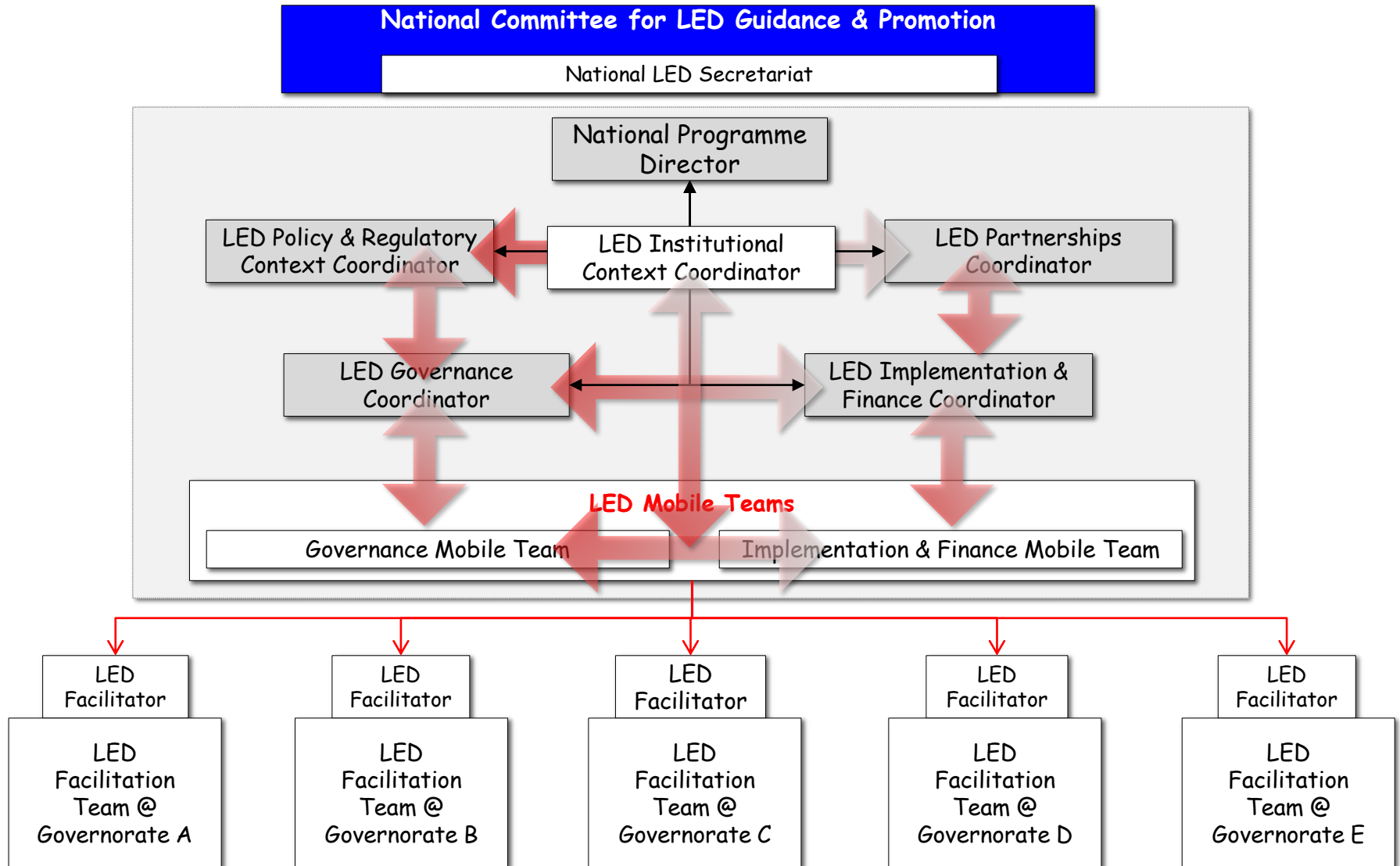

The LED promotion Process:

Local Level

The LED Promotion Process:

Scope - Local Level

Institutionalization and Capacity Development Component

Institutionalization of the LED Function & Introduction of Tools & Capacities

Local Government

LED Unit

Support & Facilitation

LED Forum

- Private Sector
- Informal Sector
- Public Sector
- CSO and NGOs
- Development Partners
- Service Sector

Economic Assessment and LED Strategy Development Phase

Quantitative/Qualitative Assessment of the Local Economy & Business Environment

Stage 1:

Local Economy Mapping

Stage 2:

Value Chain and/or Cluster Assessment or Other Thematic or Category Focused Assessments

Stage 3:

Full-fledged Local Economy & Business Environment Assessment – *Benchmark Study*

LED Strategy

LED Strategy Implementation Phase

Project Development

Project Finance

Project Implementation

Annual Implementation Program

Economic Infrastructure

SME Finance/Investment

Microenterprise finance/investment

Streamlining Regulations

Aligning Macroeconomic Policies

Skills Development & Technical Assistance

The LED promotion Process:

Institutionalizing the LED Promotion Function

The LED Promotion Framework: Institutionalization Phase:

Institutionalization of the LED Promotion Function and the Introduction of Related Tools and Capacities at Local Level

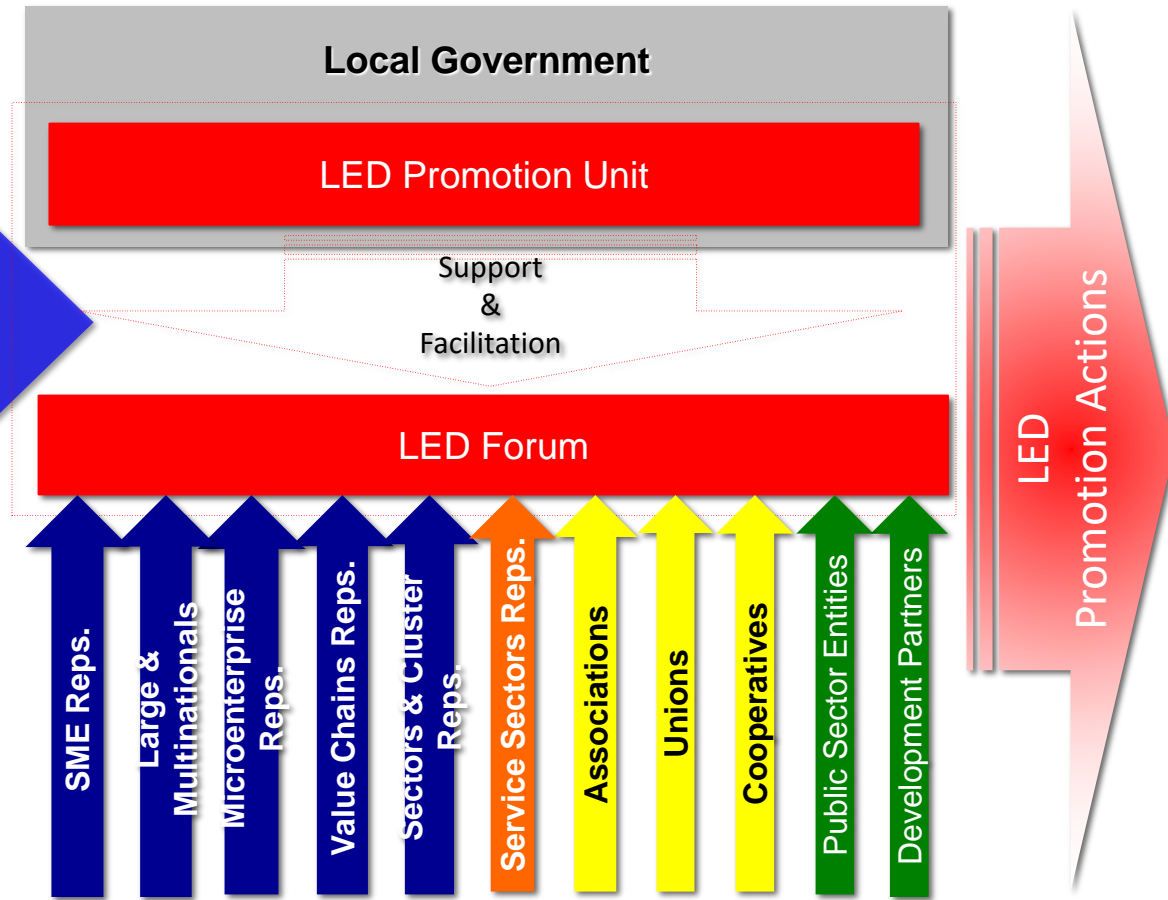

Membership of the LED Forum

The LED Promotion Process:

Institutionalization Phase – Within Local Government

- Create the LED Facilitation Team and Promotion Unit;
- Activate and Consolidate LED related Functions at the Target LG;
- Establish Working Arrangements with LED Relevant De-Concentrated Agencies:
 - Agriculture and Irrigation;
 - Trade and Industry;
 - Tourism & Antiquities;
 - Transportation;
 - Communication;
 - Electrification;
 - Public Works & Roads;
 - Vocational and Higher Education;

The LED promotion process:

Institutionalization: LED Support Team Governorate – EGYPT

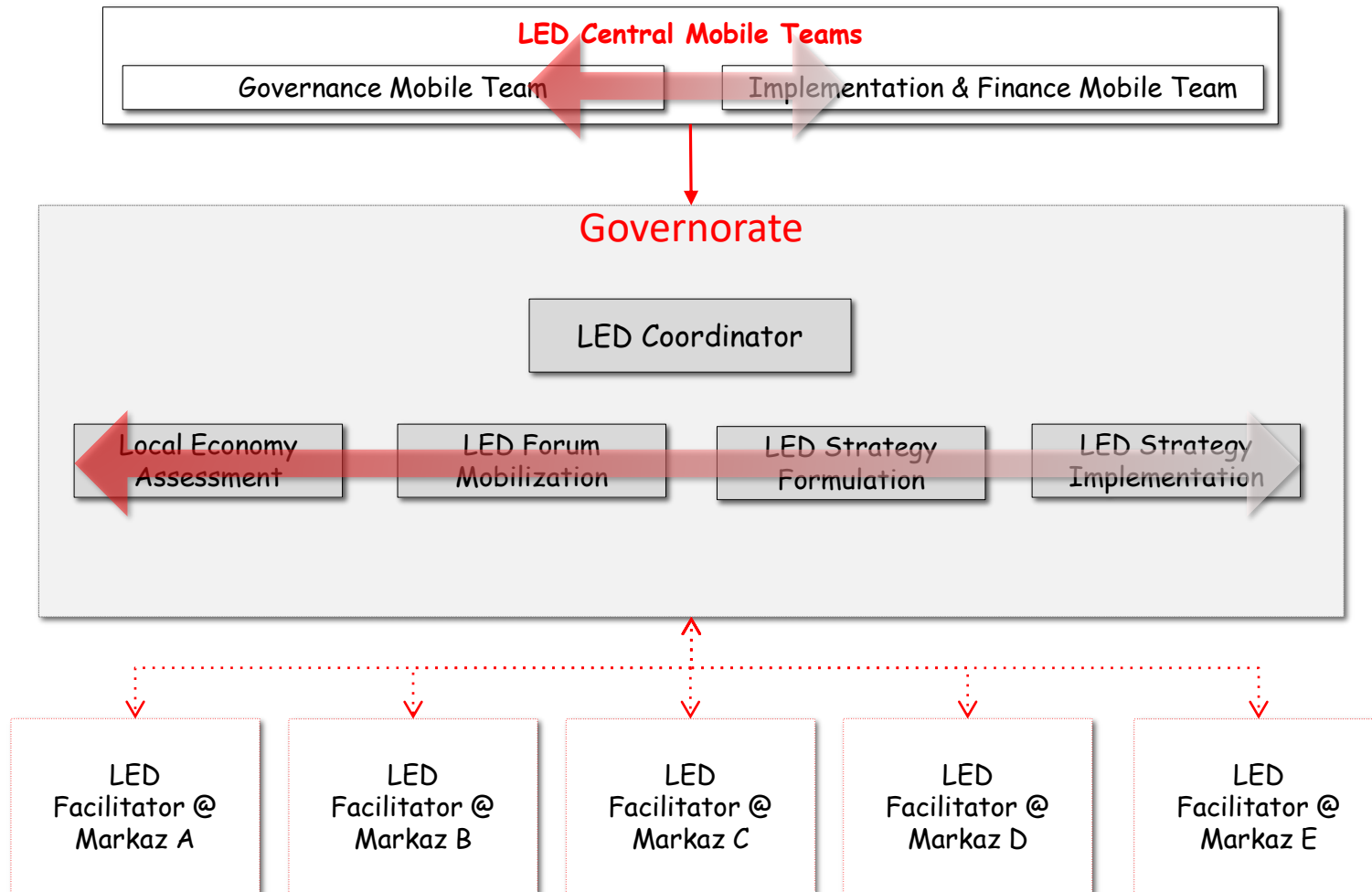

The LED Promotion Process:

Institutionalization Phase – The LED Forum

LED Forum Membership:

- Senior representation of the Local Government - Executive & Legislative;
- The LED Facilitation Team/Unit, as the Technical Secretariat of the Forum;
- LED Relevant Sector Departments;
- LED Relevant Public Agencies;
- Private sector representative organizations – Chambers, Associations, Unions, Cooperatives and others;
- Representation of the Sectors, clusters and value chains of the local economy;
- Development partners active in local economy development functions

The LED Promotion Process:

Institutionalization Phase: The LED Forum

Representative Associations, Chambers & Cooperatives of Economic Sectors, Clusters and Value & Supply Chains -
members of the LED Promotion Committee

The Local Government LED Core Management Team
Members of the LED Promotion Committee

The Local Council LED Committee
Members of the LED Promotion Committee

National & Local Economic Development Promotion Actors
(De-concentrated Sector Offices, Other Agencies & Donor Projects)
Members of the LED Promotion Committee

The Formal & Informal Local Economy, its Sectors, Clusters, Supply & Value Chains
Members of the LED Forum

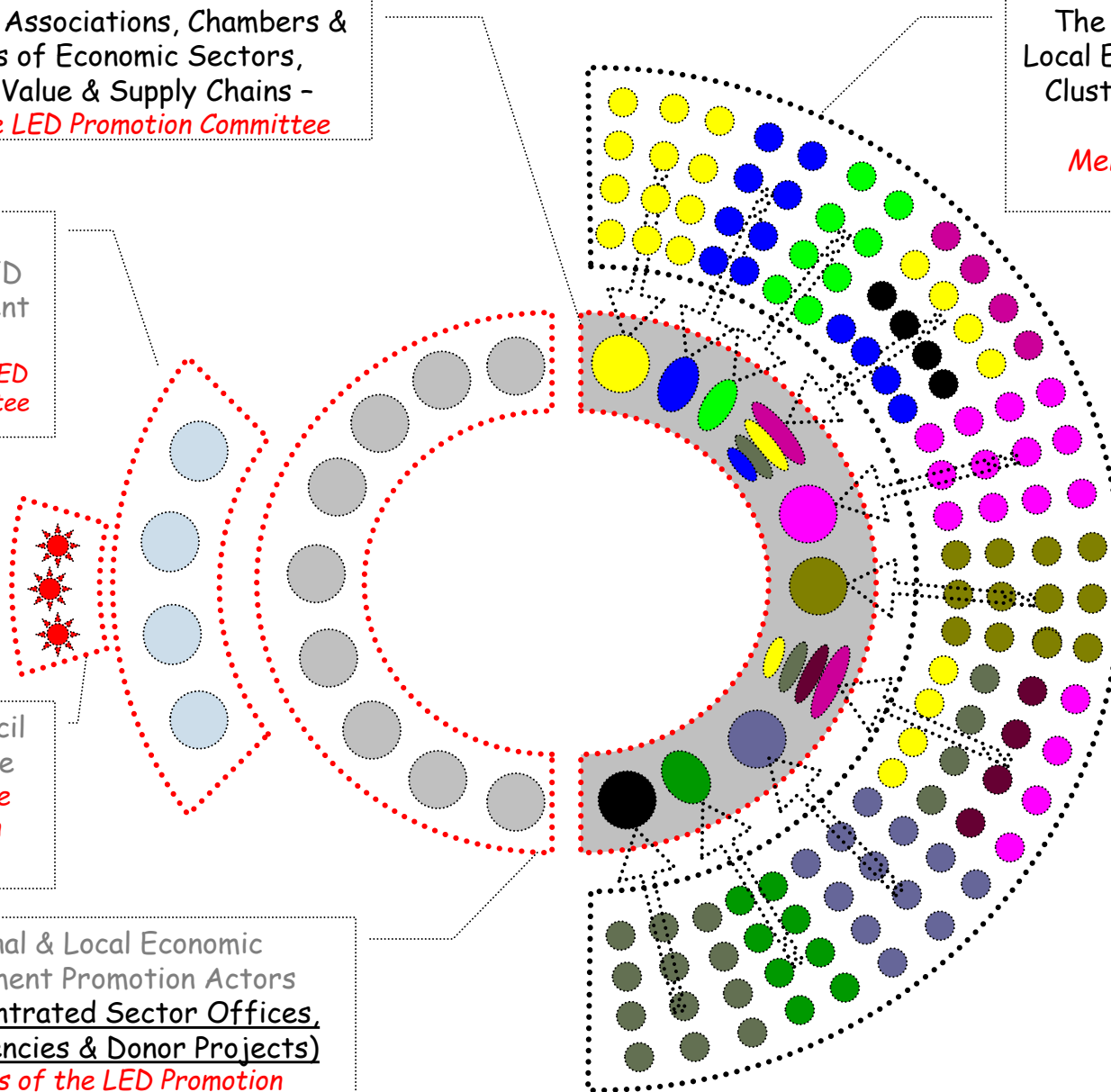

The LED promotion Process:

The Local Economy & Business Environment Assessment

The LED Promotion Process:

The Local Economy Assessment:

- Carryout a Rapid assessment of the local economy, its structure and its primary sectors, clusters and value chains and its main challenges and opportunities for growth;
- Launch the Local Economy & Business Assessment Process -
Qualitative;
- Launch the local economy data collection process
- Quantitative;

The LED Promotion Process:

The Local Economy Assessment: *Potential Scope and Areas of Focus*

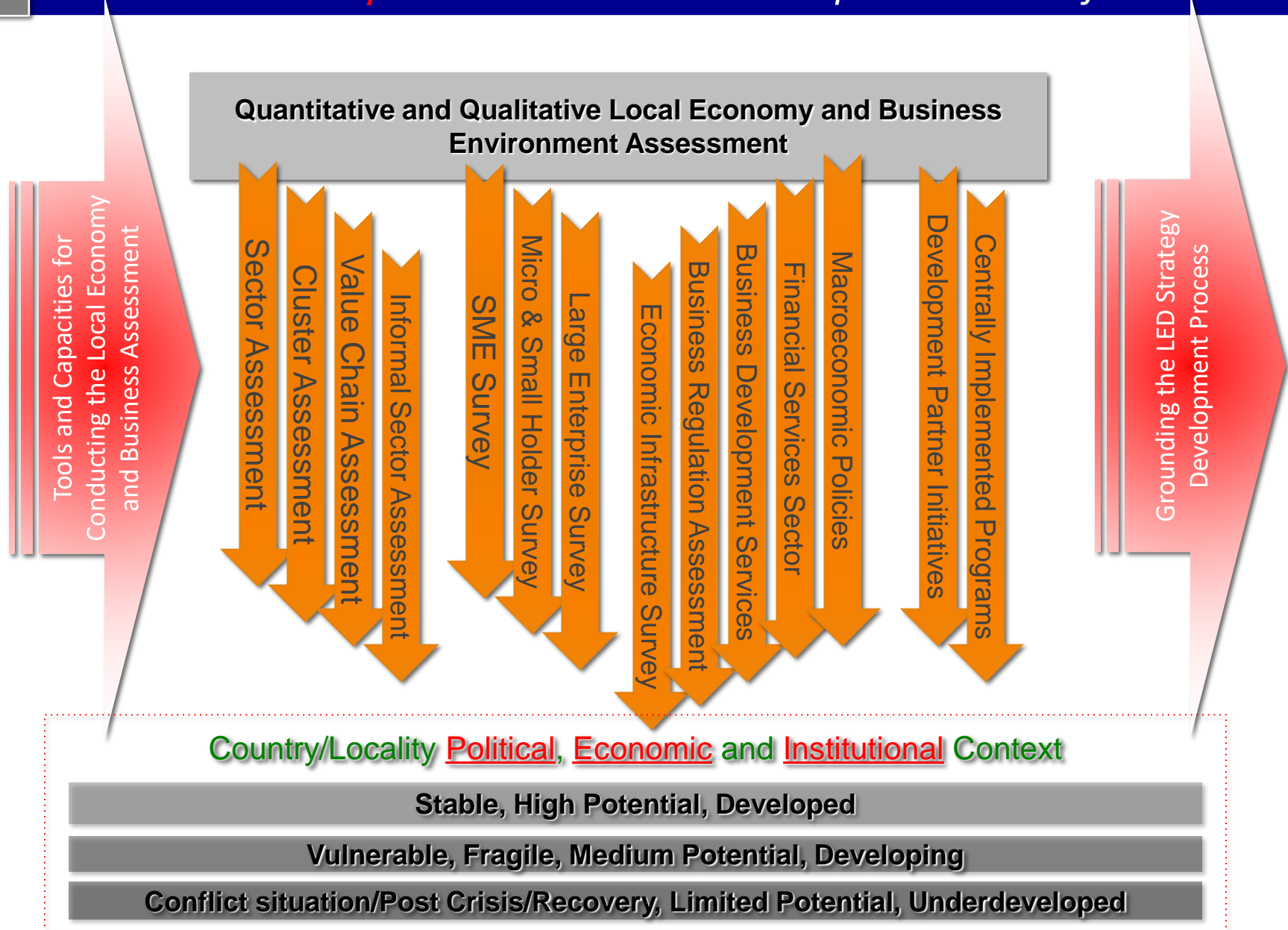

The LED Promotion Process:

The Local Economy Assessment: *Sector, Subsector, Cluster - Fayoum, Egypt*

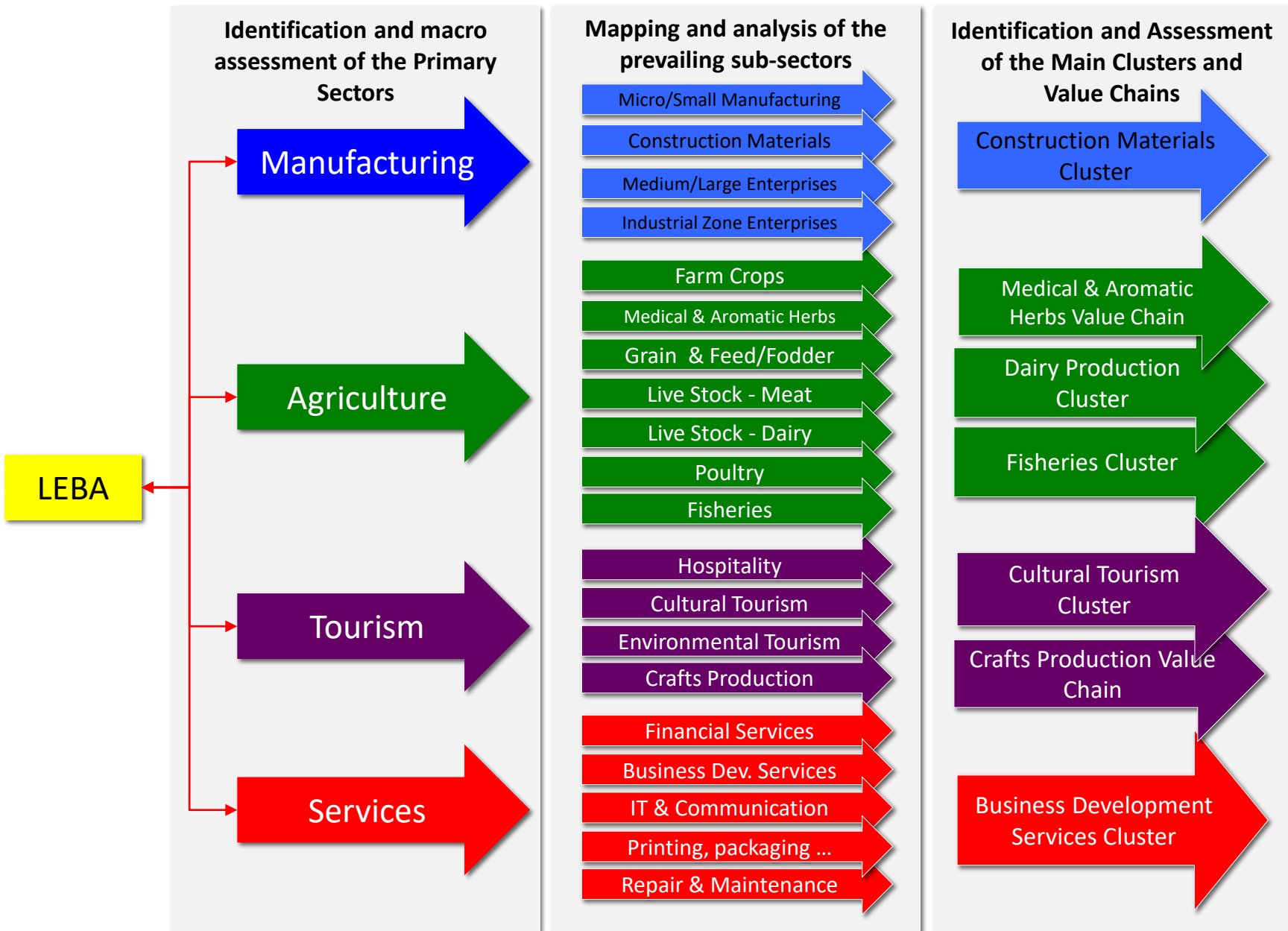

The LED promotion Process:

The LED Strategy Development Process

The LED Promotion Process:

The LED Strategy: Main Features

- 5 year and implemented annually;
- Program-based;
- Multi-sector;
- Multi-action;
- Multi-actor;
- Integrated action;

The LED Promotion Process:

The LED Strategy: Main Actors

- Local Government;
- Ministries and/or their local branches/departments;
- Public Agencies and institutions;
- The private sector – formal and informal sectors, micro, small, medium and Large Enterprises;
- Nongovernmental organizations and institutions;
- Development partners;

The LED Promotion Process:

The LED Strategy: Intervention Typology

- Economic infrastructure – roads, electricity, irrigation, markets, etc....;
- Service sector projects – communication, transportation, etc...;
- Private sector micro, small, medium of large investments/projects;
- Technical assistance;
- Skills development;
- Improvement to regulations;
- Alignment or improvement to macroeconomic policies;
- Other

The LED Promotion Process: The LED Strategy: Vision to Programs

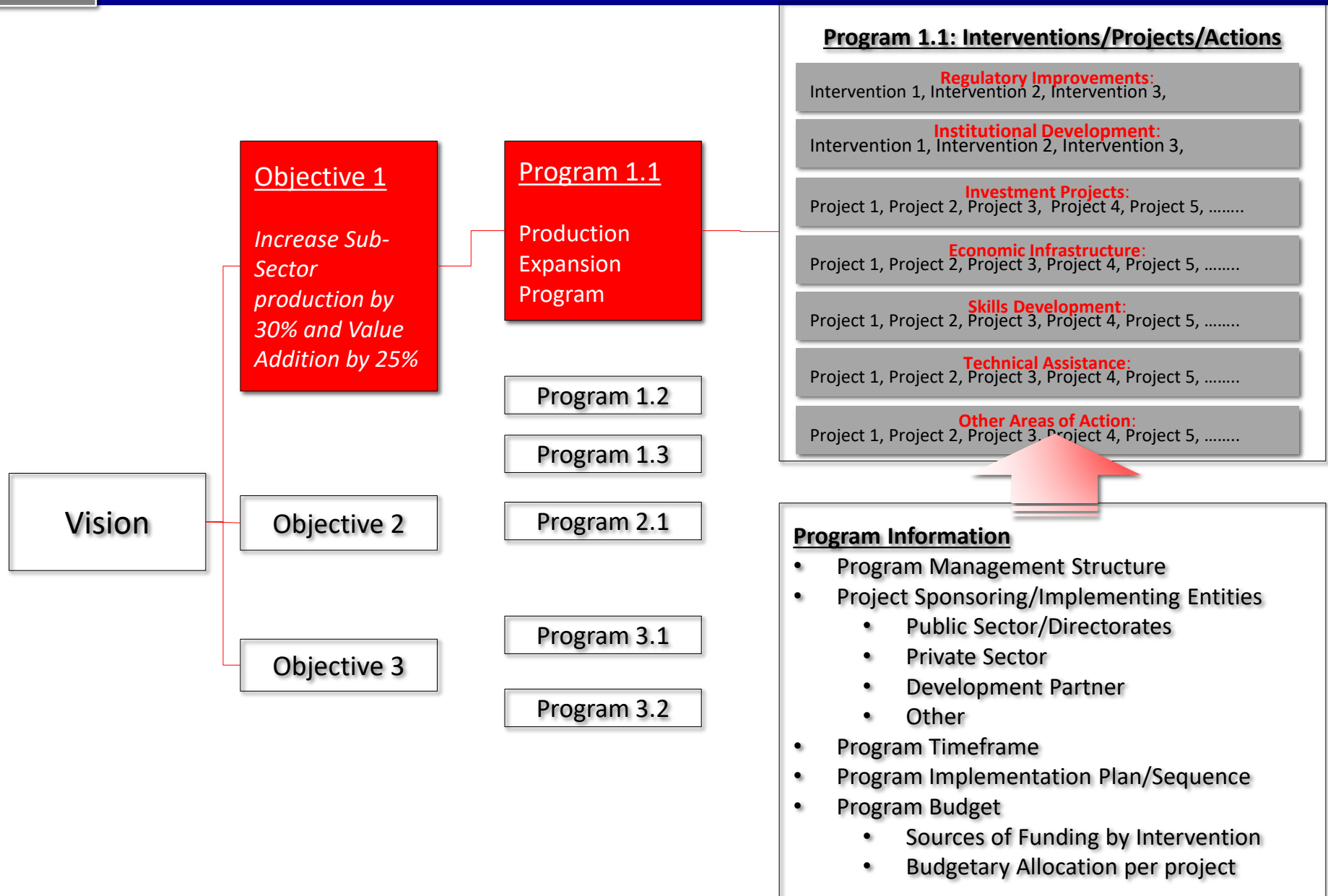

The LED Promotion Process:

The LED Strategy: Structure and Potential Scope

Intervention Typology

Economic Infrastructure Projects

Service Sector Projects

Micro & Small Holder Projects

Small & Medium Production Enterprise

Large-Scale Production Projects

Skills Development Programs

Technical Assistance Programs

Policy Alignment Interventions

Regulation Streamlining Interventions

Program Based LED Strategy

Cultural Tourism Cluster Development Program

Construction Material Cluster Development Program

Dairy Cluster Development Program

Agricultural Production Value Addition Program

Crafts Development & Export Promotion Program

Organic Agriculture Development Program

Linkage Development Program Between Local SMEs & Industrial Zone Manufacturers

Local Transport Sector Development Program

Governorate Renewable Energy and Energy Efficiency Enhancement program

The LED Promotion Process:

The LED Strategy: Mapping the Dairy Cluster

Define Scope and components of the Cluster

Example Subsector: **Dairy Production Cluster**

- Cattle breeding activity
- Processed/industrial feed production and supply
- Agricultural feed production
- Veterinary care provision and veterinary medicine production or supply
- Milk production process
- Milk quality and inspection and health certification services
- Raw milk packaging process and systems & Raw milk storage
- Raw milk collection and transportation – transportation services
- Financial services and finance to the milk producing livestock sector
- Infrastructure including livestock farm infrastructure and facilities, storage, transshipment facilities, markets, roads, power, water relevant to livestock sector
- Milk processing – into cheese, yogurt and other
- Dairy production machinery and equipment sources
- Skills development sources for dairy production
- Specialized technical support services to dairy production & product development services
- Health and quality inspection/control and certification services
- Packaging suppliers
- Marketing services – national, regional and international
- Financial services and finance for the dairy sector
- Infrastructure including cold storage, collection facilities, roads, power, water, waste water and solid waste management systems
- Sector departments supporting and regulating dairy production and the livestock sector
- Livestock sector policies, laws and regulations
- Dairy sector policies, laws and regulations
- Tariff and market entry agreements
- Livestock and Dairy related research and development sources
- Other



**Dairy
Cluster
Scope of
Activities &
Inputs**

The LED Promotion Process:

The LED Strategy: The Dairy Cluster Development Programme

Identify and Categorize Interventions

Sub-Programme – Dairy Production

Economic Infrastructure:

- improve infrastructure supporting the milk producing livestock and Dairy subsector including:
 - Roads – Specific locations
 - Markets, storage systems
 - electric supply – Specify location and served community
 - water and sanitation systems & solid waste management – Specific location

Technical Assistance:

- improve milk producing livestock variety, quality & productivity
- Strengthen Organic farming technical support – specific providers
- Improve marketing channels – local, regional or international

Skills Development:

- enhance the skill of milk producing livestock sector personnel

Institutional Development:

- Strengthening or creation of specialized association
- Improve Public Extension Services – Specify institution location

Investment in New or Existing Production Activities:

- Interventions/investments to improve feed quality and supply
- investments to improve raw milk storage and dispensing systems
- improve milk quality inspection and monitoring services and capacities
- Interventions/investments to enhance the quality of support services to the milk producing livestock sector
- Interventions/investments to improve and expand milk collection, storage and redistribution systems

Finance & Financial Services:

- Support the introduction of bridge finance facilities for Livestock farmers
- Avail access to finance to serve the finance needs of dairy producers
- Develop access to equity investment in dairy production



Dairy Cluster
Intervention
Programme

The LED promotion Process:

The LED Strategy Implementation Process

The LED Promotion Process:

The LED Strategy Implementation Process:

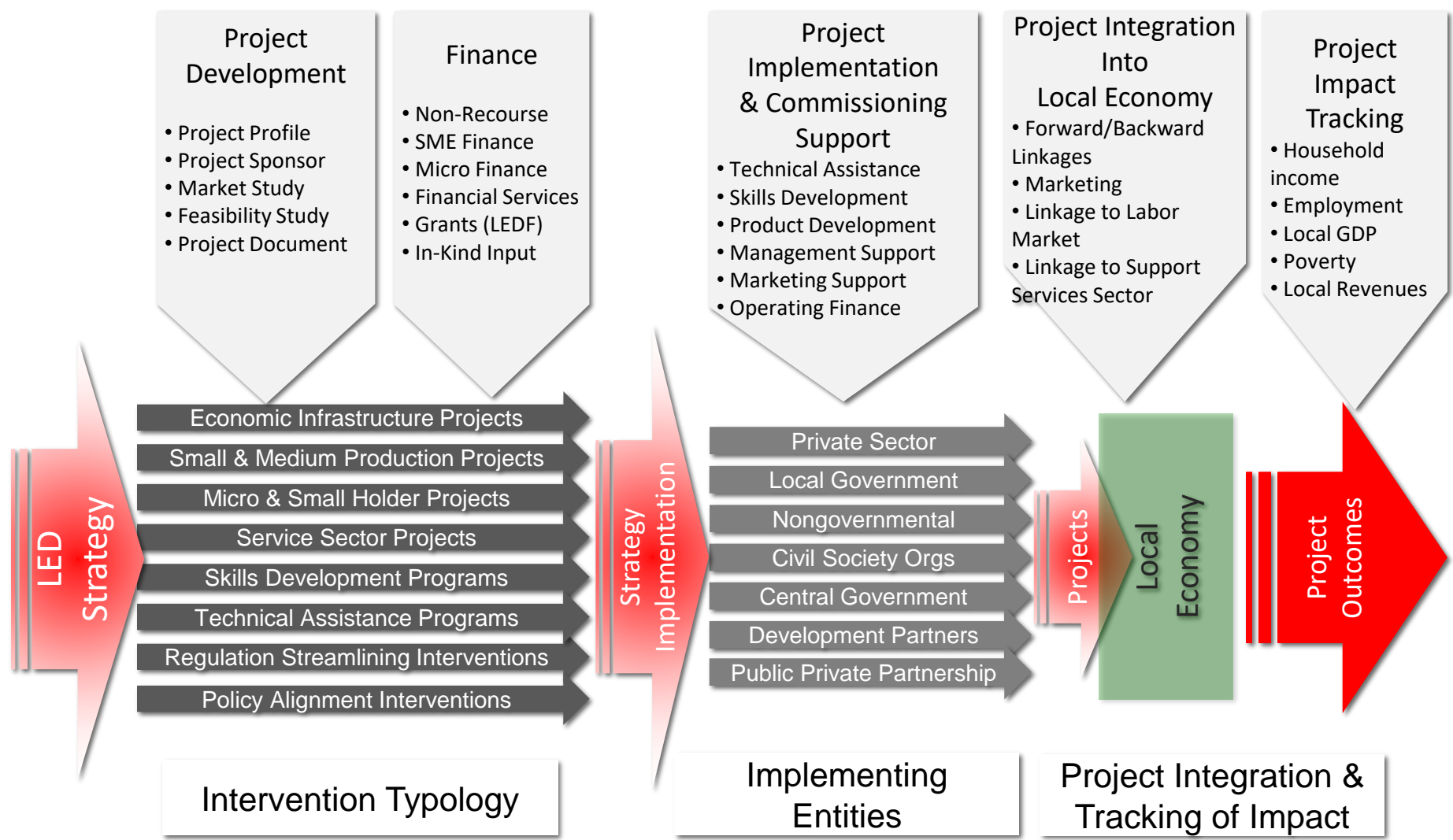

The LED Promotion Process:

LED Strategy Implementation: Project Development Phase

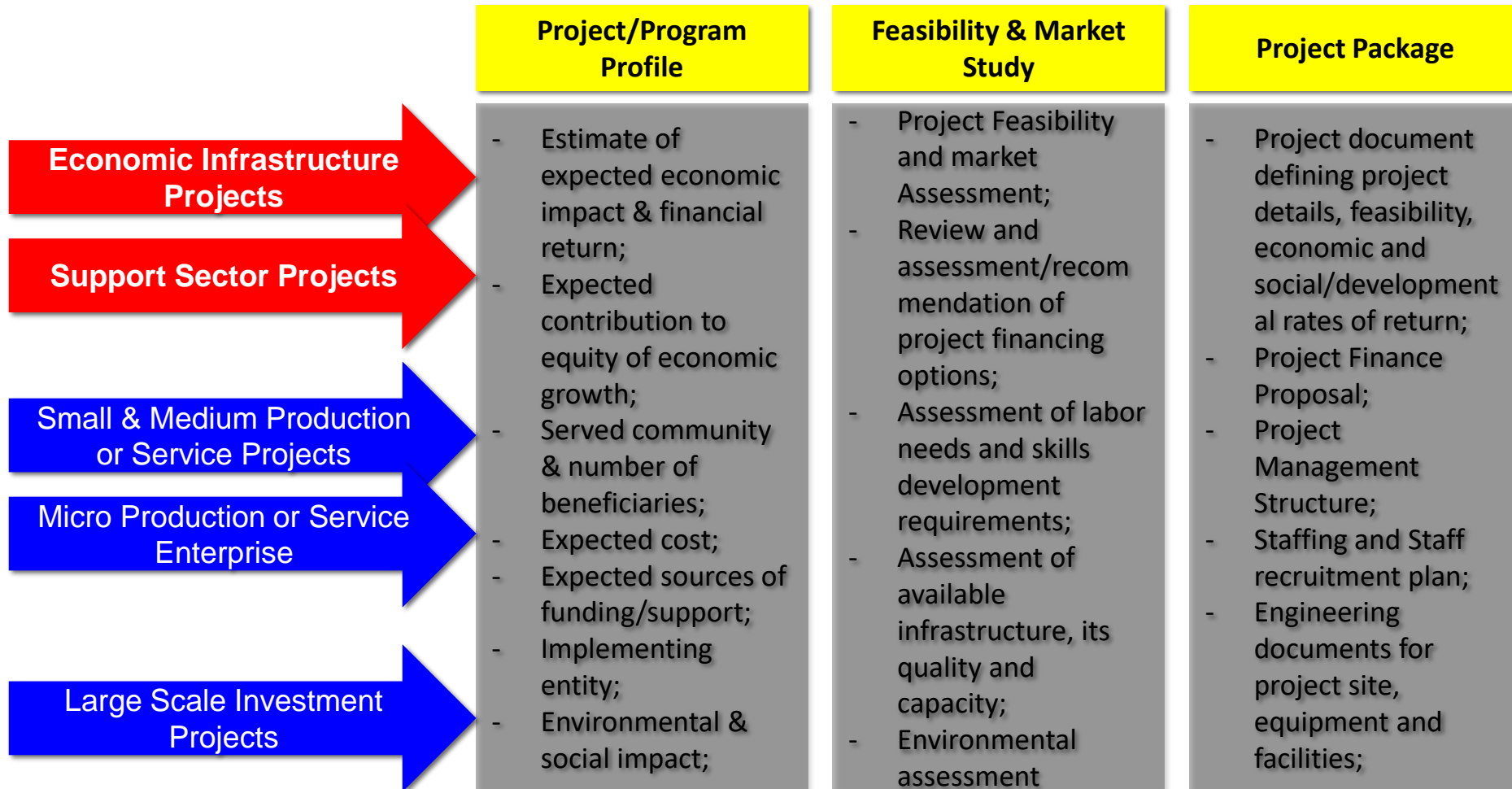

The LED Promotion Process:

LED Strategy Implementation: Project Development Phase

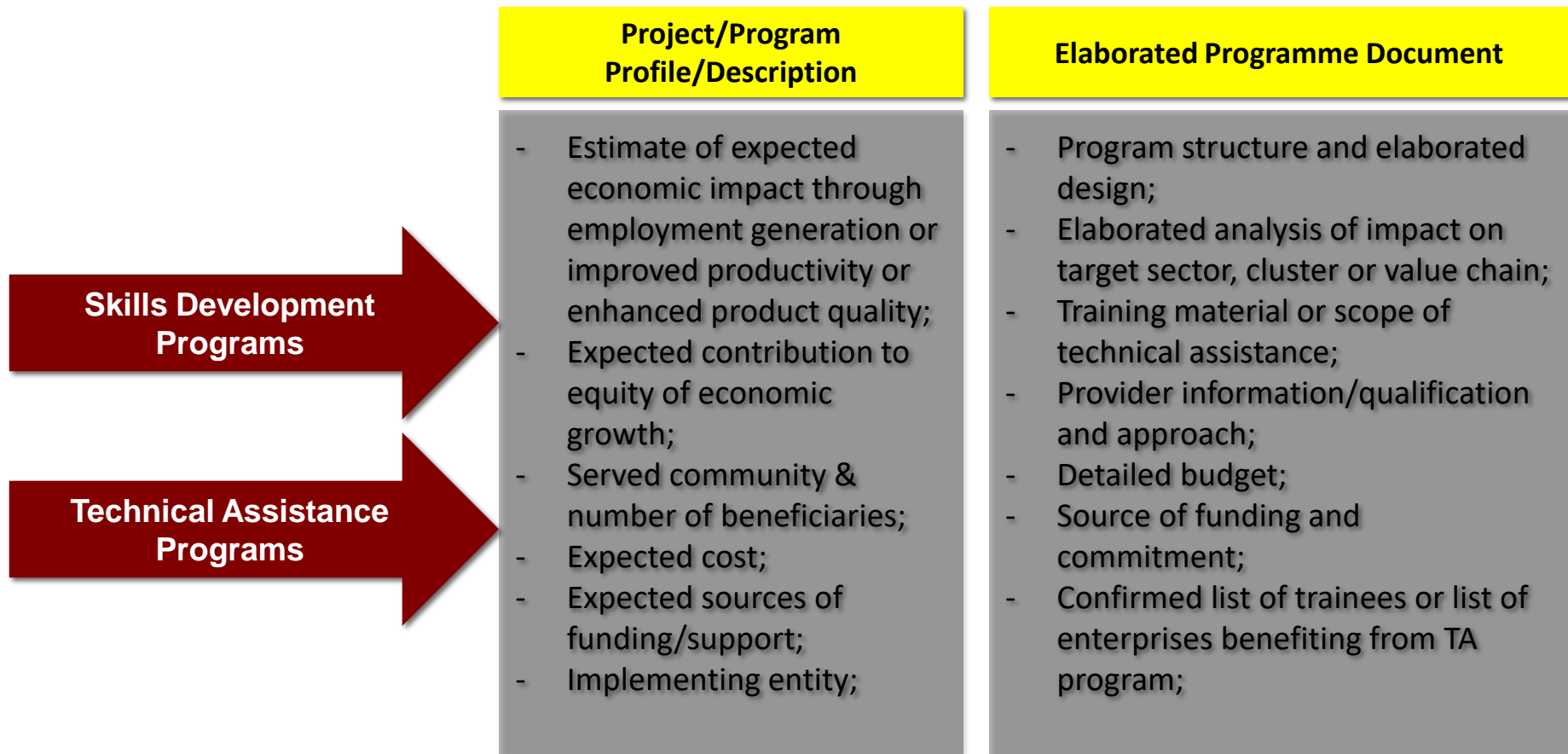

The LED Promotion Process:

LED Strategy Implementation: Project Development Phase

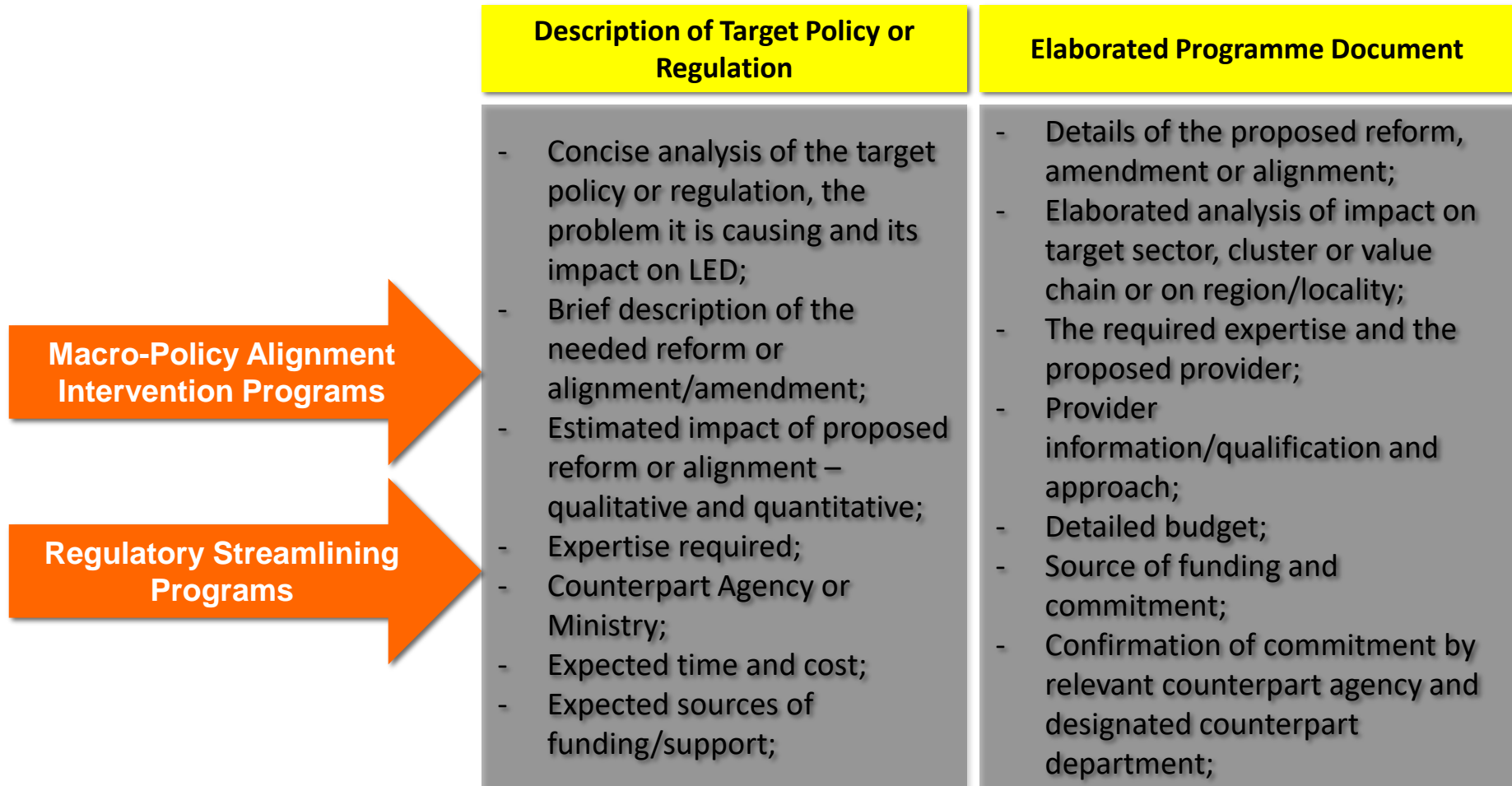

The LED promotion Process:

LED Strategy Implementation: Project Finance Phase

The LED Promotion Process:

LED Strategy Implementation: Finance – Economic Infrastructure

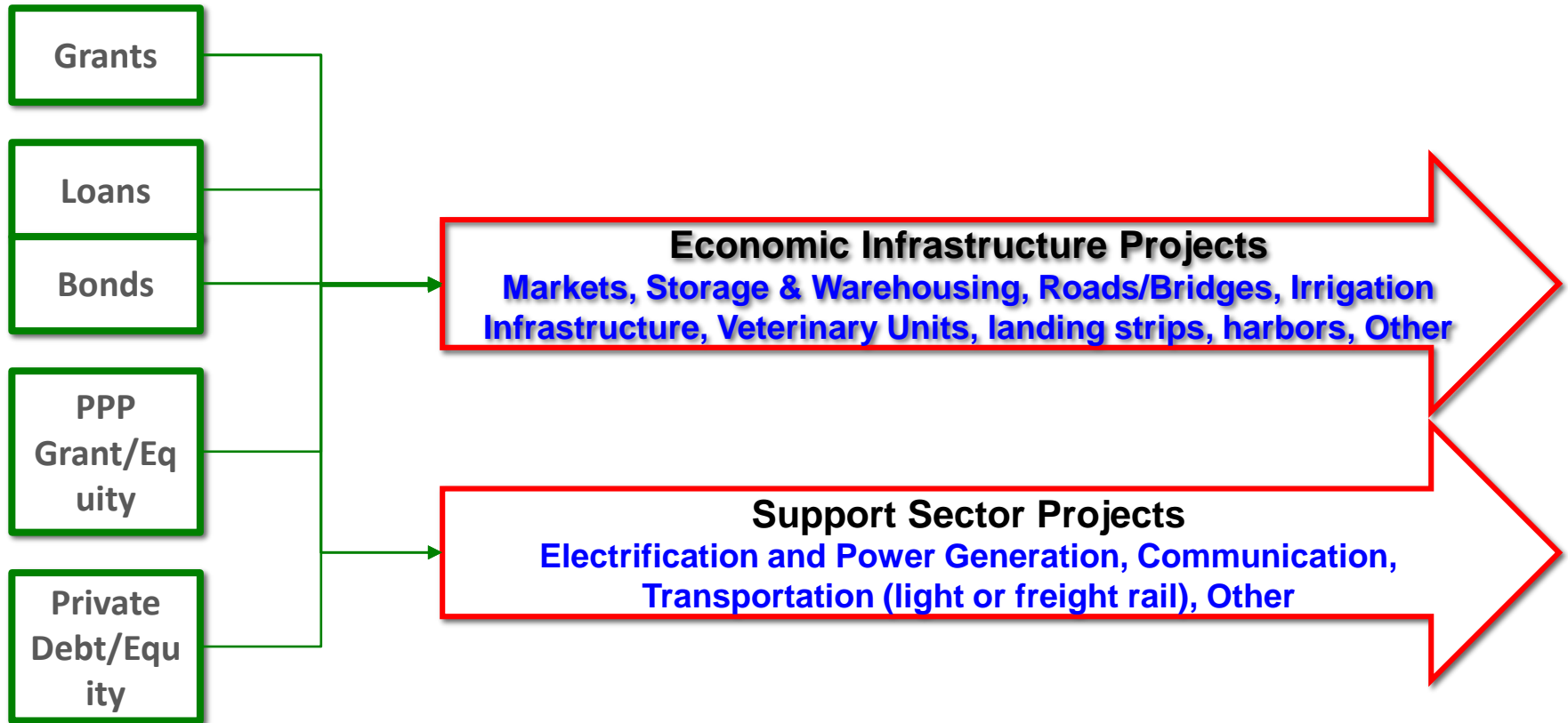

The LED Promotion Process:

LED Strategy Implementation: Finance – Enterprise Investment

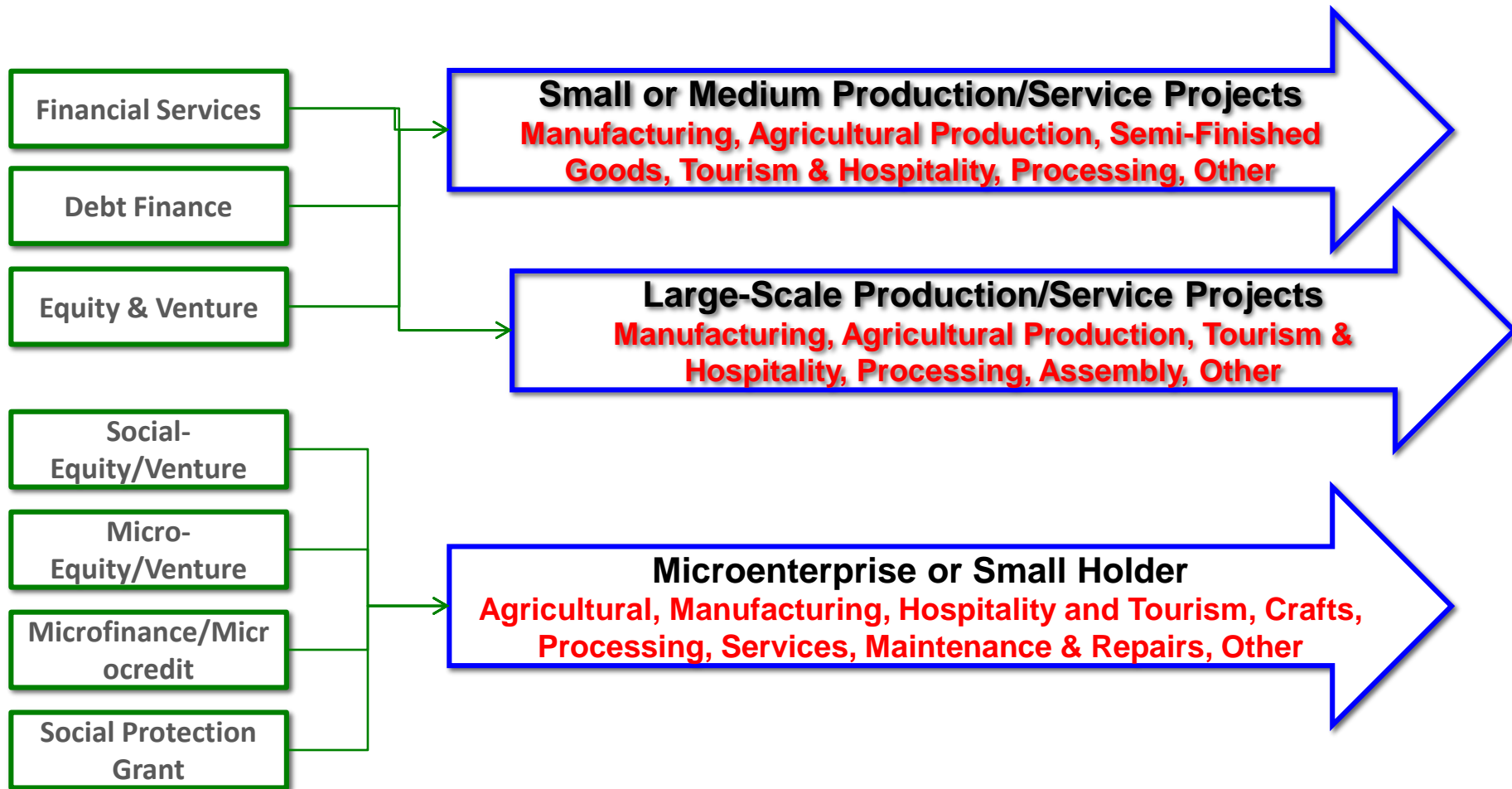

The LED Promotion Process:

LED Strategy Implementation: Finance of Skills Development

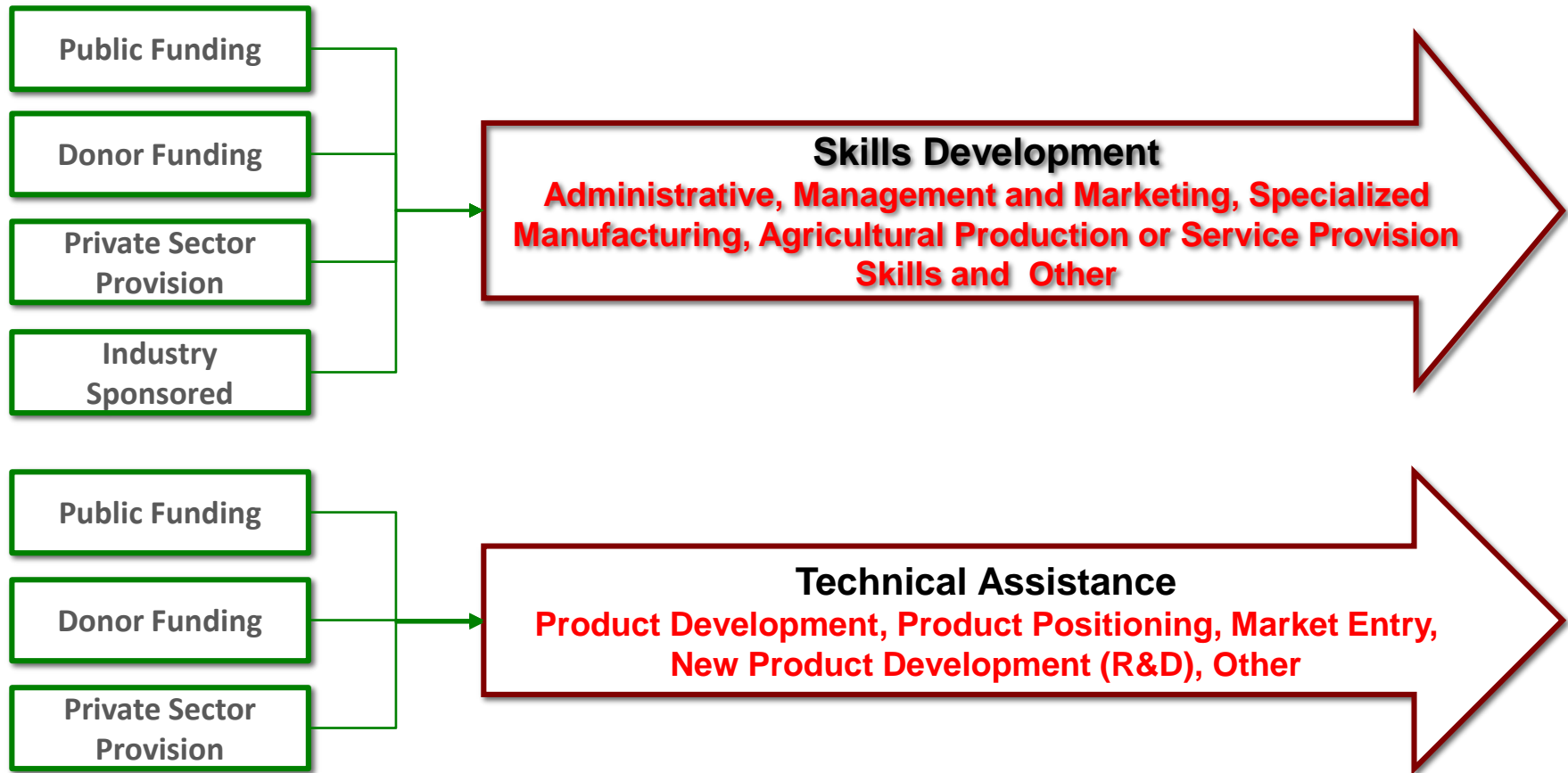

The LED Promotion Process:

Strategy Implementation: Finance of Policy & Regulatory Interventions

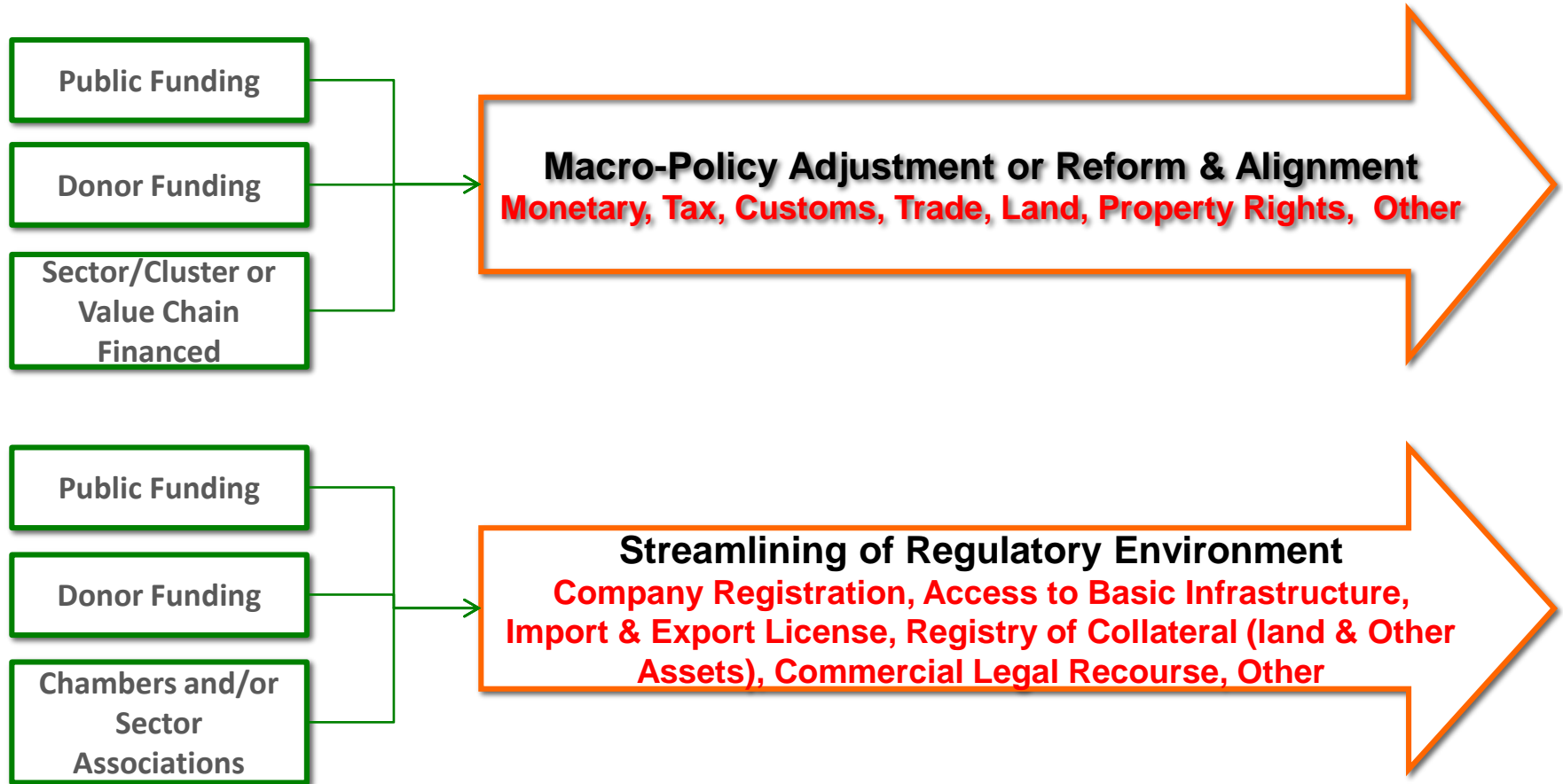

The LED promotion Process:

Sources of LED Finance:

The LED Promotion Process:

Sources of LED Finance: Public Sources

- *De-concentrated and Centrally Allocated Public Financial Flows in LED Relevant Sectors: Agriculture, Industry, Trade, Communication, Transportation and Roads, Electrification, Water and Irrigation;*
- *National Sector Strategy Allocations in the Above Sectors that are Typically Managed Centrally and Implemented the Parallel Modalities;*
- *Public Sector **Funds** that are Capitalized through Public Resources or through Development Partner/External Sources;*
- *Public Development Banks & Finance or Financial Services Agencies;*
- *Development Partner Allocations and Financial and Finance Instruments – Grants, Loans and Risk Guarantees and Credit Enhancement Instruments*

The LED Promotion Process:

Sources of LED Finance: Private Sources

- *Commercial Banks and Bank Deposits and other Private Debt Finance Sources;*
- *Microfinance and Microcredit Institutions;*
- *Pension Funds and other Employee Savings Institutions;*
- *Insurance Companies;*
- *Private Equity Funds and Holding Companies;*
- *Venture Capital Funds – Social Venture, Angel Investors;*
- *Remittances and FDI Sources*

The LED Promotion Process:

LED Finance Needs: The Demand Side

- *Economic Infrastructure – Roads, Bridges, Markets, Public & Commercial Transport Facilities Warehouses, Irrigation Water Supply Systems, Harbors, landing Strips, Power Generation and Distribution, and Other;*
- *Strategic Support Sector Infrastructure – Communication, Transportation, ICT, Energy (including Renewable – Solar & Wind) and others;*
- *Micro, Small and Medium Enterprises – In Agriculture, Industry/Manufacturing, Tourism, Processing, Assembly, Services and Other;*
- *Large-Scale Catalytic Enterprises – Large Scale Manufacturing, Assembly or Processing Plants or Tourism Enterprises;*

The LED promotion Process:

The LED Fund:

The LED Promotion Process:

The LED Fund: Finance Tools

- **Grants** – *Performance Grants to Local Government to Supplement Own Sources of Finance for LED, to be Used to Build LG Capacity for Managing and Effectively Allocating Public Funds, and to Leverage Increased of Central Funding for LED promotion;*
- **Loans** – *To Local Governments, Securitized Through Income Generated by LG Investments that have Utilized the Loan;*
- **Risk or First-Loss Guarantees** – *To Private Sources of Debt and Equity Finance (in collaboration or Partnership with other Available Risk Mitigation Facilities) with the Goal of Leveraging Private Investment Flows in LED Promotion;*
- **Credit Enhancement** – *To Private Sector Investors to Enhance their Credit Assessment/Rating to enable them to Access Suitable Finance;*

The LED Promotion Process: The LED Fund: Structure and

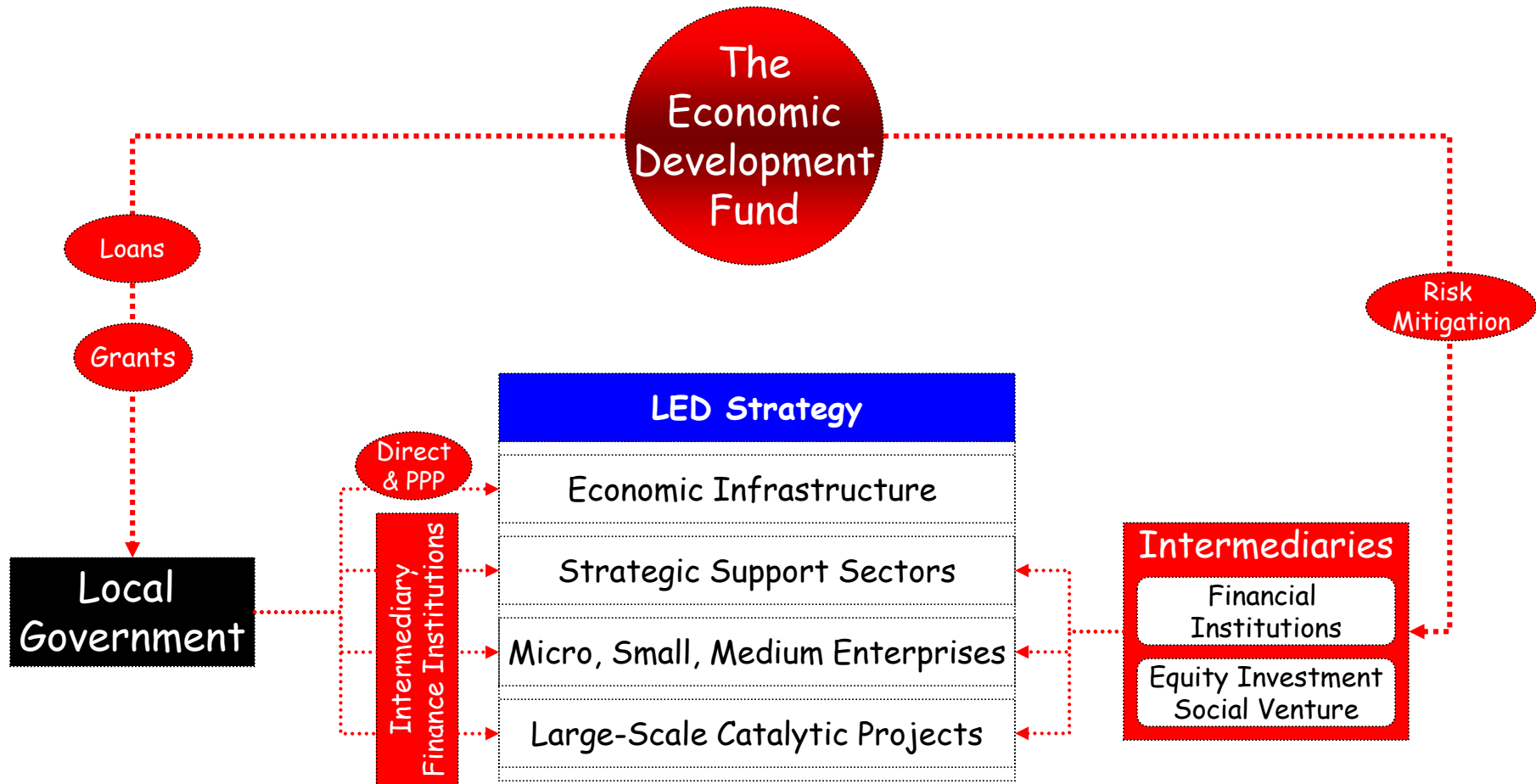

The LED Promotion Process:

The LED Fund: Financing Private Enterprises and PPP

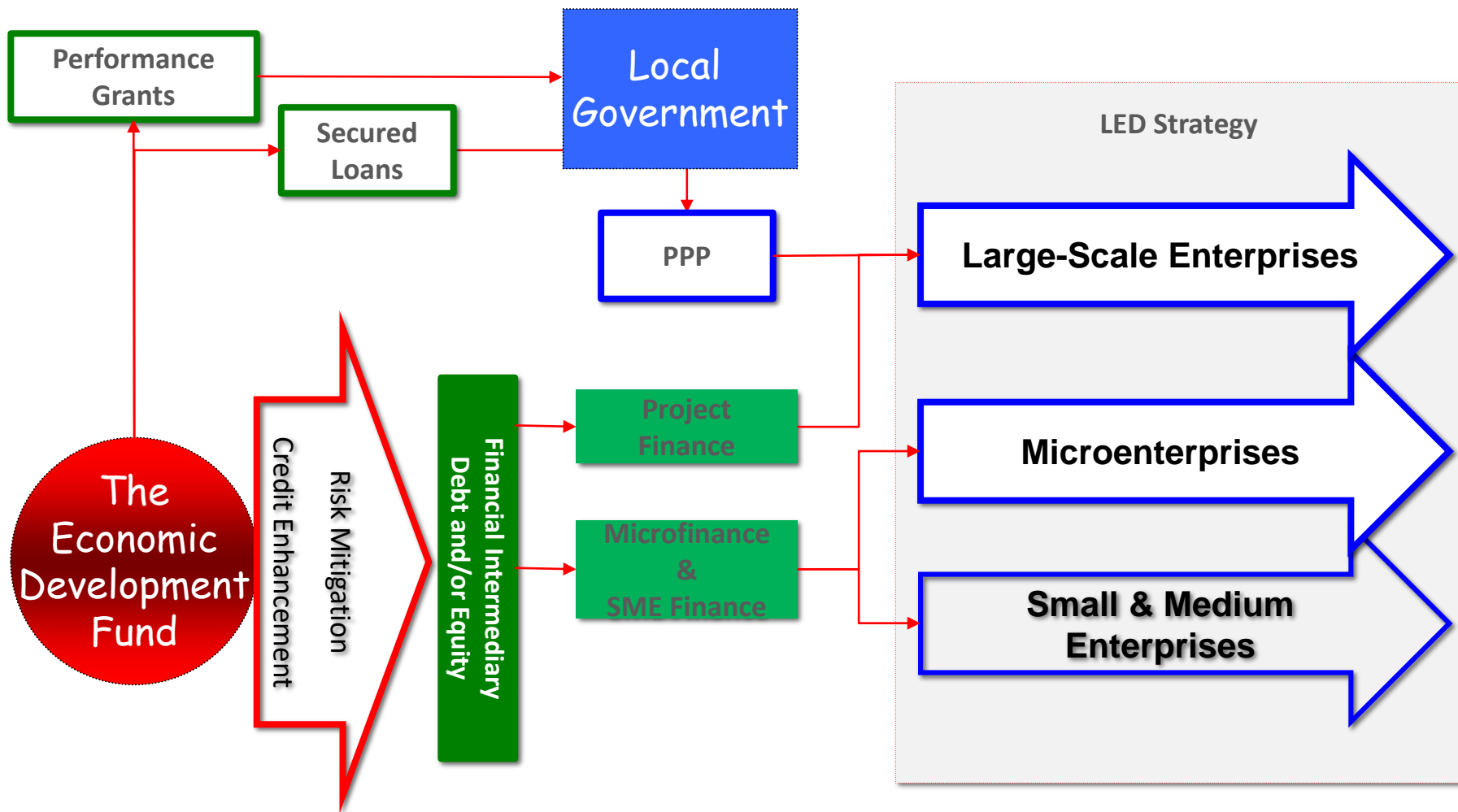

The LED Promotion Framework:

Consolidating/Integrating LED Promotion Efforts – National & Local

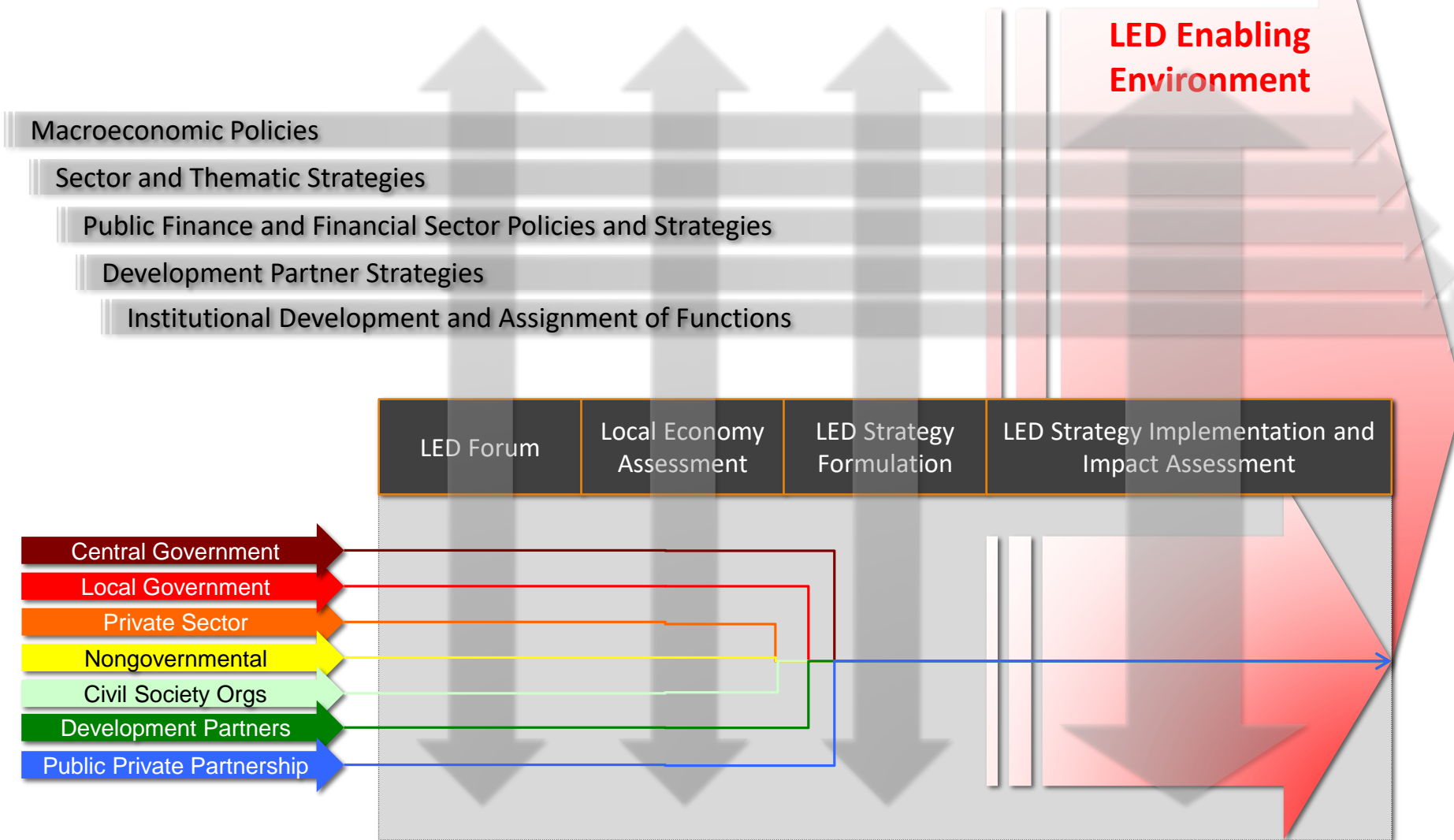

Reference and source

1. Implementing Sustainable Development: From Global Policy to Local Action by Phillip J. Cooper and Claudia Maria Vargas | Apr 5, 2004
2. Promoting Sustainable Local and Community Economic Development (ASPA Series in Public Administration and Public Policy) by Roland V. Anglin | Apr 15, 2011
3. Cultural Tourism and Sustainable Local Development (New Directions in Tourism Analysis) 1st Edition, by Luigi Fusco Girard (Editor), Peter Nijkamp (Editor)
4. Carrots Don't Grow on Trees: Building Sustainable and Resilient Communities by Robert Turner | Feb 15, 2019
5. Sustainability and Resilience Planning for Local Governments: The Quadruple Bottom Line Strategy (Sustainable Development Goals Series) Part of: Sustainable Development Goals Series (17 Books) | by Haris Alibašić | Jun 19, 2018



Thank You!