

ENERGY, ENVIRONMENT AND SOCIETY

Chapter - 15

Energy Storage

Assoc. Prof. Manchan Tiwari

Kathmandu Engineering College

Nepal

LEARNING OBJECTIVES OF THE LECTURE

- Basics of energy storage
- Characteristics of energy storage
- Types of energy storage systems

ENERGY STORAGE

- Energy storage is required to maintain the balance between energy production and demand.
- Energy storage means storing the energy produced to be used later in any form.
- The most common example of the energy storage device is battery which is used extensively.
- The energy storage devices are more important for the energy sources such as solar and wind which are not continuous and are intermittent.

TYPES OF ENERGY STORAGE

- The energy storage devices can be classified into
- Mechanical energy storage
 - Flywheel energy storage
 - Pumped hydro energy storage
 - Compressed air energy storage
- Thermal and thermochemical energy storage
- Electrical energy storage
 - Battery storage
 - Magnetic field energy storage

CHARACTERISTICS OF ENERGY STORAGE

The characteristics of energy storage systems can be measured by following terms

- Storage capacity
- Energy density
- Charging and discharging rate
- Storage duration
- Storage efficiency
- Economics, initial cost, life span and payback period

CHARACTERISTICS OF ENERGY STORAGE

Storage capacity

Storage capacity is defined as the maximum energy capacity that a system can store in one cycle. An energy storage system consists of a reservoir which contains a storage medium. A hot water storage system has the following capacity.

$$E = m \times C_p \times (t_i - t_f) \text{ [kJ]}$$

Where

- E is the energy stored
- m is the mass of water in kg
- C_p is the specific heat capacity of water in J/kg K
- t_i is the initial temperature in Kelvin and
- t_f is the final temperature in Kelvin

CHARACTERISTICS OF ENERGY STORAGE

Energy density

Energy density is the amount of energy that can be stored in a device or medium in a given system, substance or space. It can also be defined as the energy stored per kg mass or per m³ volume of the storage medium. It can be expressed as

$$e = E/m \text{ [kJ/kg]}$$

where,

- e is the energy density
- m is the mass in kg

In some cases energy per unit mass is labeled as specific energy and energy per unit volume is termed as energy density.

CHARACTERISTICS OF ENERGY STORAGE

Fuel Type	Energy Density (MJ/kg)
Wood	16
Coal	24
Ethanol	26.8
Crude Oil	44
Diesel	45
Gasoline	46
Natural gas	55
Uranium-235	3,900,000

Energy Density of some fuel (Singal, 2011)

CHARACTERISTICS OF ENERGY STORAGE

Storage system/medium	Type of energy stored	Energy density (W-h/kg)
Water	Sensible heat	58
Iron	Sensible heat	8
Flywheel	Mechanical	20-30
Pumped hydro	Mechanical	0.82
Lead Acid Battery	Chemical	40
Ni-Cd	Chemical	100

Energy Density of some systems (Singal, 2011)

CHARACTERISTICS OF ENERGY STORAGE

Charging and discharging rate

Charging rate is the rate at which the energy can be supplied to the storage system where as discharging rate is the rate at which energy can be withdrawn from the storage system per unit time.

CHARACTERISTICS OF ENERGY STORAGE

Storage duration

The operating cycle of a storage system consists of the time period required for charging, time period for the storage of the energy in the system and the time period for the discharging of the energy that is withdrawal of the energy to the consumer. The total sum of these duration is known as storage duration.

Storage efficiency

It is defined as the ratio of discharged energy to the charged energy

TYPES OF ENERGY STORAGE

Storage of mechanical energy

Flywheel storage

Any rotating circular mass keeps on rotating unless acted upon by external force due to its inertia.

Flywheel is a circular disc kind of structure which is attached to a motor generator set and an enclosure.

The rotating mass acts as storage medium and energy is stored as kinetic energy of flywheel.

TYPES OF ENERGY STORAGE

Storage of mechanical energy

Flywheel storage

During charging the motor adds energy to the flywheel and during discharging, the energy is generated to cover the peak load.

Basically, the shape of a flywheel is a circular disc or a circular ring (Singal, 2011).

$$E = \frac{1}{2} I \omega^2$$

$$I = \frac{1}{2} m r^2$$

Where

- I is the moment of inertia of flywheel in kg/m^2
- ω is the angular velocity in s^{-1}
- m is the mass in kg
- r is the radius in m

TYPES OF ENERGY STORAGE

Storage of mechanical energy

Flywheel storage

$$e = k \left(\frac{\sigma}{\rho} \right)$$

Where,

- e is the energy density in J/kg
- k is the shape factor from 0 to 1
- σ is the allowable yield stress of flywheel in N/m²
- ρ is the density of the material

TYPES OF ENERGY STORAGE

Storage of mechanical energy

Flywheel storage

The value of energy density of a flywheel depends on the size, shape and material of flywheel.

Titanium has the highest energy density when used in flywheel of the value of 220 kJ/kg. composite materials can give higher energy density.

Glass and epoxy in circular rings flywheel can give energy density of 450 kJ/kg and graphite/epoxy can give energy density of 540 kJ/kg (Singal, 2011).

TYPES OF ENERGY STORAGE

Storage of mechanical energy

Pumped Hydro Storage

A pumped hydro storage consists of an upper reservoir and a lower reservoir connected by a pressure pipe line.

When the power demand is low, the water is pumped from lower to upper reservoir by spare power and during the peak load or high demand period, the stored water is used to generate extra power.

TYPES OF ENERGY STORAGE

Storage of mechanical energy

Compressed Air Energy Storage

A compressed air energy storage system consists of following components:

- An air compressor
- Motor-generator set
- Air cooler
- Underground air reservoir
- Gas turbine
- Combustion chamber

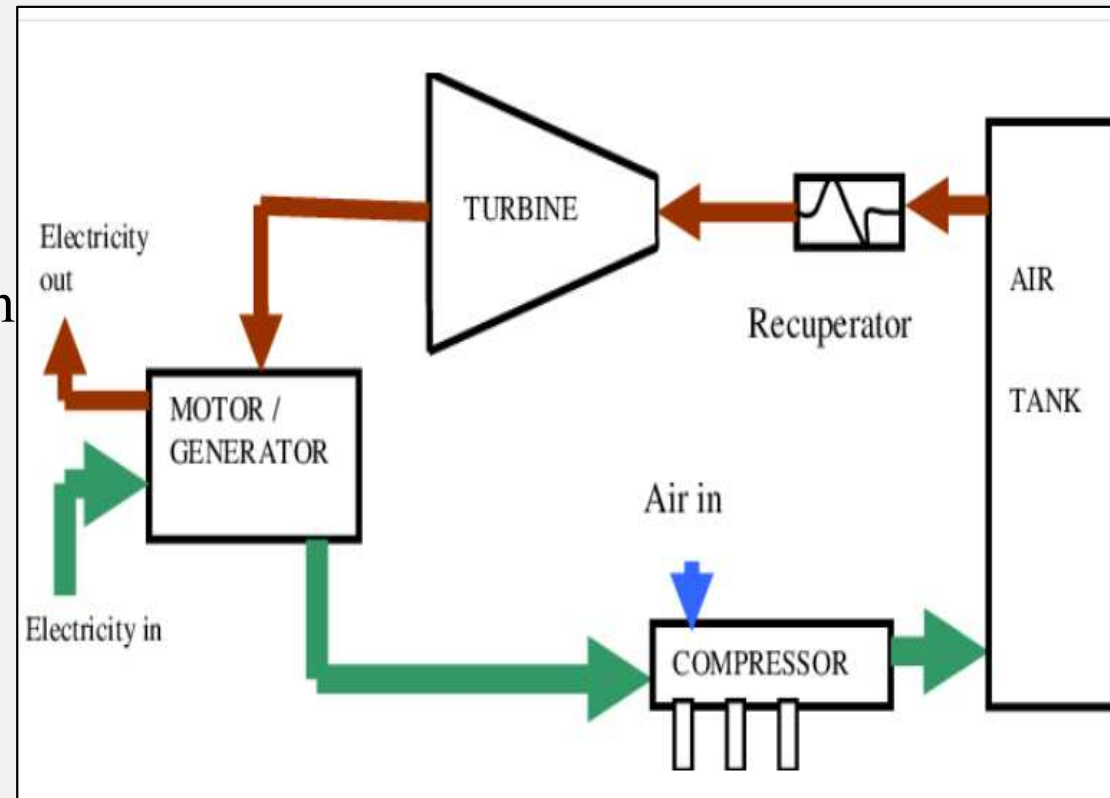

Compressed Air Energy Storage (Researchgate, 2022)

TYPES OF ENERGY STORAGE

Storage of mechanical energy

Compressed Air Energy Storage

- When the electrical demand is low, the spare power is used to drive air compressor with the help of motor. The cooled air is stored in the underground reservoir. When the demand is high, the compressed air from the underground is used to drive gas turbine to meet the peak loads (Singal, 2011).

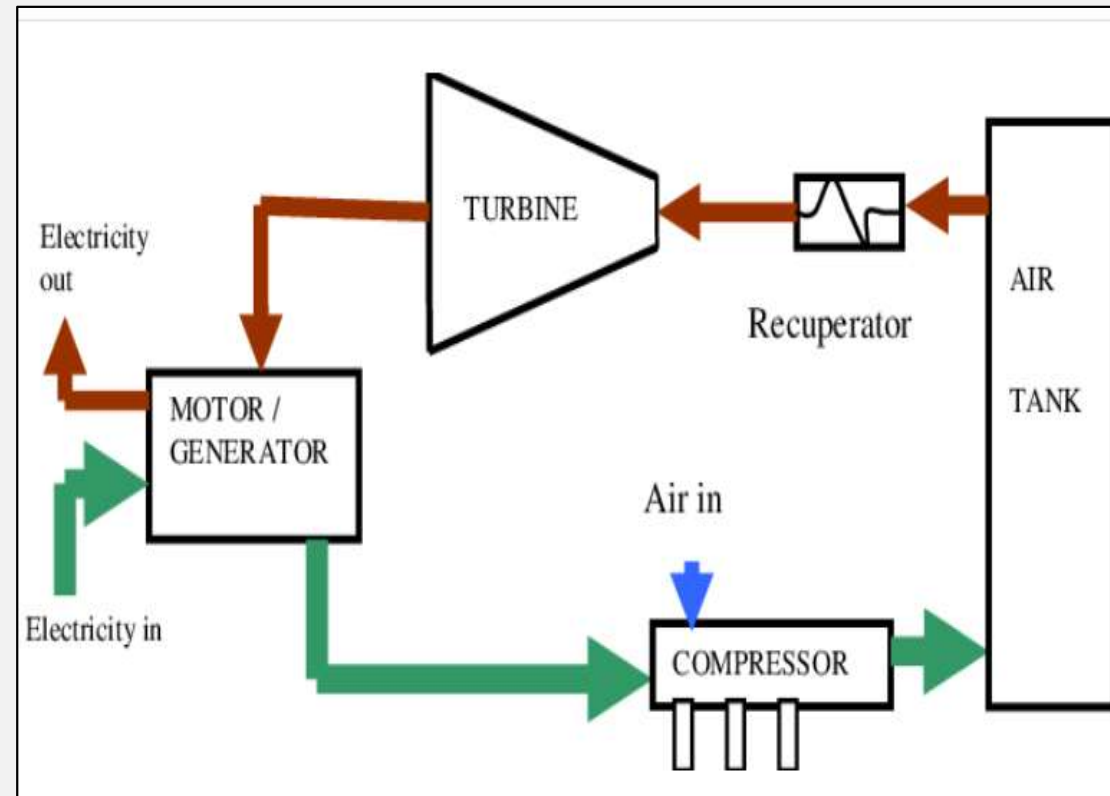

Compressed Air Energy Storage (Researchgate, 2022)

TYPES OF ENERGY STORAGE

Electrochemical energy storage (Battery)

An electrochemical cell or a battery consists of two electrodes and electrolyte in a box.

When the cathode and anode are interconnected externally through a resistance, electrochemical reaction takes place in the cell.

Lead-acid batteries, nickel cadmium batteries and other batteries are used to store electrical energy.

TYPES OF ENERGY STORAGE

Electrochemical energy storage (Battery)

An electric battery is a device consisting of one or more electrochemical cells that convert stored chemical energy into electrical energy.

Each cell contains a positive terminal, or cathode, and a negative terminal, or anode.

Electrolytes allow ions to move between the electrodes and terminals, which allows current to flow out of the battery to perform work (Sedhai, 2015).

TYPES OF ENERGY STORAGE

Electrochemical energy storage (Battery)

- Primary (single-use or "disposable") batteries are used once and discarded; the electrode materials are irreversibly changed during discharge.
- Common examples are the alkaline battery used for flashlights and a multitude of portable devices. Secondary (rechargeable batteries) can be discharged and recharged multiple times; the original composition of the electrodes can be restored by reverse current.
- Batteries have much lower specific energy (energy per unit mass) than common fuels such as gasoline.
- This is somewhat offset by the higher efficiency of electric motors in producing mechanical work, compared to combustion engines

TYPES OF ENERGY STORAGE

Electrochemical energy storage (Battery)

Principal of operation

Batteries convert chemical energy directly to electrical energy.

A battery consists of some number of voltaic cells.

Each cell consists of two half-cells connected in series by a conductive electrolyte containing anions and cations.

One half-cell includes electrolyte and the negative electrode, the electrode to which anions (negatively charged ions) migrate; the other half-cell includes electrolyte and the positive electrode to which cations (positively charged ions) migrate.

TYPES OF ENERGY STORAGE

Electrochemical energy storage (Battery)

Principal of operation

Cations are reduced (electrons are added) at the cathode during charging, while anions are oxidized (electrons are removed) at the anode during discharge.

The electrodes do not touch each other, but are electrically connected by the electrolyte. Some cells use different electrolytes for each half-cell.

A separator allows ions to flow between half-cells, but prevents mixing of the electrolytes.

TYPES OF ENERGY STORAGE

Electrochemical energy storage (Battery)

Principal of operation

The voltage developed across a cell's terminals depends on the energy release of the chemical reactions of its electrodes and electrolyte.

If a charger cannot detect when the battery is fully charged then overcharging is likely, damaging it.

Disposable batteries typically lose 8 to 20 percent of their original charge per year when stored at room temperature (2030_C).

This is known as the "self-discharge" rate.

TYPES OF ENERGY STORAGE

Electrochemical energy storage (Battery)

Principal of operation

Battery life can be extended by storing the batteries at a low temperature, as in a refrigerator or freezer, which slows the side reactions.

Such storage can extend the life of alkaline batteries by about 5%; rechargeable batteries can hold their charge much longer, depending upon type.

TYPES OF ENERGY STORAGE

Electrochemical energy storage (Battery)

Principal of operation

The C-rate is a measure of the rate at which a battery is being discharged.

It is defined as the discharge current divided by the theoretical current draw under which the battery would deliver its nominal rated capacity in one hour.

A 1C discharge rate would deliver the battery's rated capacity in 1 hour. A 2C discharge rate means it will discharge twice as fast (30 minutes).

A 1C discharge rate on a 1.6 Ah battery means a discharge current of 1.6 A. A 2C rate would mean a discharge current of 3.2 A.

TYPES OF ENERGY STORAGE

Thermal energy storage.

It refers to methods that are used to store thermal energy in order to use it to cool or heat buildings when the temperature inside is above or below the internal energy in the stored substance.

Hot water storage tank.

It refers to a water tank that stores hot water for space heating, washing, bathing, etc.. Hot water storage tanks are a common feature of wood furnaces and solar thermal collectors.

TYPES OF ENERGY STORAGE

Storage heater.

It is an electric heater that stores energy during the evening or night and releases heat during the day when the price of base load electricity is higher. Storage heaters work by accumulating heat in ceramic material or clay bricks.

Steam accumulator.

It refers to a steel tank that contains steam under pressure. It is used to balance between supply and demand by accepting steam when the supply is greater than demand and to release it when demand exceeds the supply.

TYPES OF ENERGY STORAGE

Supercapacitor

A supercapacitor (SC), sometimes ultracapacitor, formerly electric double-layer capacitor (EDLC)) is a high-capacity electrochemical capacitor with capacitance values up to 10,000 farads at 1.2 volt that bridge the gap between electrolytic capacitors and rechargeable batteries.

They typically store 10 to 100 times more energy per unit volume or mass than electrolytic capacitors, can accept and deliver charge much faster than batteries, and tolerate many more charge and discharge cycles than rechargeable batteries.

TYPES OF ENERGY STORAGE

Supercapacitor

They are however 10 times larger than conventional batteries for a given charge.

The amount of energy a capacitor is capable of storing can be increased by either increasing the capacitance or the voltage stored on the capacitor.

The stored voltage is limited by the voltage with stand strength of the dielectric.

As with batteries, the turnaround efficiency when charging/discharging capacitors is also an important consideration, as is response time.

The effective series resistance of the capacitor has a significant impact on both (Sedhai, 2015).

TYPES OF ENERGY STORAGE

Supercapacitor

The supercapacitor is ideal for energy storage that undergoes frequent charge and discharge cycles at high current and short duration.

Supercapacitors or double-layer capacitors (DLCs) as they are also known, contain a significantly enlarged electrode surface area compared to conventional capacitors.

Supercapacitors are capable of very fast charging and discharging times, and are able to go through many cycles without degradation.

Typical efficiencies for supercapacitors are high (85-98%) making them an attractive storage technology for many applications, however currently these are mostly small-scale (Sedhai, 2015).

REFERENCES

- Boyle, G. (2013). *Renewable Energy Power For A Sustainable Future* (Vol. Third Edition). Oxford: Oxford University Press.
- Chmielewski, A. G. (1999). *Environmental Effects of Fossil Fuel Combustion*. Warszawa: Institute of Nuclear Chemistry and Technology.
- *Energy Education*. (2022). Retrieved November 14, 2022, from https://energyeducation.ca/encyclopedia/Fuel_cell
- S. Hasan, S., & Sharma, D. (2009). *Non-Conventional Energy Resources*. Delhi: S. K. Kataria and Sons.
- Sedhai, S. (2015). *IOE Notes on EES*. Institute of Engineering, Central Campus.
- Singal, R. (2011). *Non-Conventional Energy Resources* (Vol. Third Edition). Delhi: S. K. Kataria and Sons.
- *Wikipedia*. (2022). Retrieved November 14, 2022, from https://en.wikipedia.org/wiki/Electric_battery

THANK YOU